

PM5900 POWERMOVER

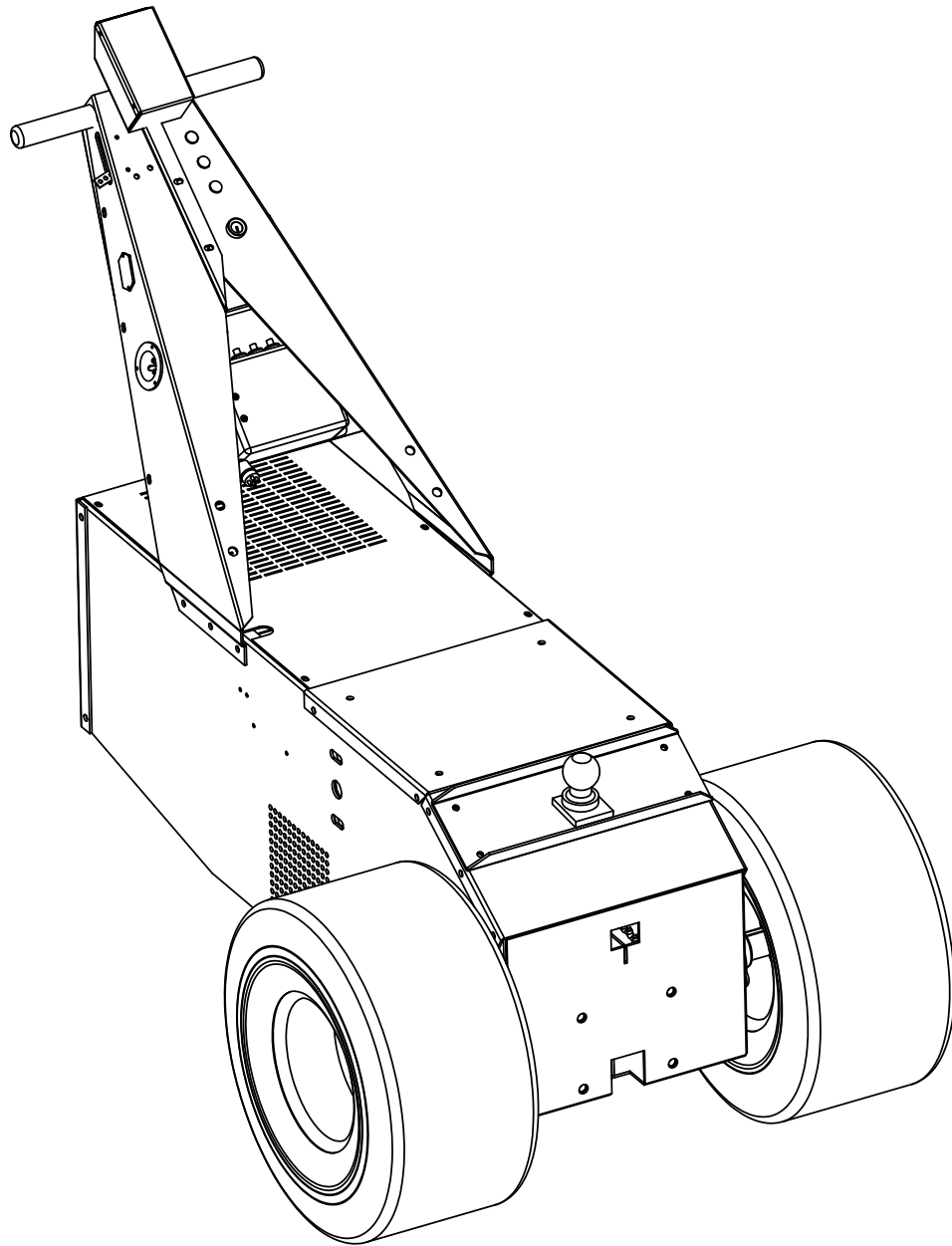

OPERATION, MAINTENANCE & PARTS MANUAL

Ultra-Fab Products Inc.
57985 State Road 19 South
Elkhart, Indiana 46514
PH: 800-860-7571
FX: 800-860-4980
Email: Customerservice@ultra-fab.com
Web Site: ultra-fab.com

INTRODUCTION

Dear Customer

Congratulations and thank you for purchasing a Powermover by Ultra-Fab. It is our intent to provide you with the best possible product we can build, backed up by excellent customer service.

We realize, as with any power equipment, that the user of our products will need assistance from time to time. Please feel free to call or fax our customer service department. Our technicians are eager to serve you in any way possible. Phone: 800-860-7571 Fax: 800-860-4980 E-mail customerservice@ultra-fab.com Web site: www.ultra-fab.com

Please take time to read and understand your operation manual before putting your Powermover into service. Please follow the service guide lines set forth in the manual to ensure the best possible care of your Powermover. Failure to perform the necessary maintenance on a timely basis could result in unnecessary repairs and customer dissatisfaction.

Please remember we appreciate your business and are here to serve you.

Sincerely

Darryl Searer/President

TABLE OF CONTENTS

BASIC OPERATION

Warning-----	3
Keyed Switch-----	3
Variable Speed Control-----	3
Forward & Reverse-----	3
Hydraulic Switches-----	3
Brake Control-----	3
Braking-----	3
Charging System-----	3
Steering-----	4
Hydraulic Lift-----	4
Hour Meter-----	4
Options-----	4
Safety Recommendation-----	4

GENERAL MAINTENANCE

Motors-----	5
Grease Fittings-----	5
Batteries-----	5
Hydraulic Fluid Level-----	5
Chains-----	5
Tires-----	5

REPLACING PARTS

Recommendations-----	5
Motors-----	6
Belts-----	6
Shaft 3 -----	6
Tires-----	7
Chains-----	7
Differential-----	7
Hydraulic Pump-----	7
Hydraulic Cylinders-----	7

PARTS BREAKDOWN

WIRING DIAGRAMS

BASIC OPERATION

WARNING

Your Powermover was designed to move heavy objects and loads on nearly level surfaces.

Do not operate on slopes.

KEYED SWITCH

Your Powermover requires a key to turn the ignition switch on. Be sure to turn the key to the off position when your Powermover is not in use.

VARIABLE SPEED CONTROL

The speed control is operated with the right index finger and has a one second delay built into it. When you pull the speed control lever you will hear a click and experience a short delay before the Powermover begins to move. Do not pull the speed control lever to its maximum position until you get the feel of how the Powermover accelerates. The procedure should be slow at first and then faster as you become more experienced. **Caution: Before pulling the speed control lever be sure the forward/reverse switch is in the desired position.**

FORWARD/REVERSE SWITCH

This is a simple rocker type switch and can be operated by using your right thumb. **Caution: Make sure you have selected the desired direction before activating the switch.**

HYDRAULIC SWITCH (OPTIONAL)

Your Powermover may be equipped with a hydraulic lift. If it has a lift there is a switch on the handle to control the up/down motion of the mast. Pull back on the switch to raise the mast and push forward on the switch to lower the mast. Note: The switch is spring-loaded and requires you to hold the switch on until the mast reaches the desired height.

BRAKE CONTROL (OPTIONAL)

If your Powermover has the seven way connector mounted on the top front of the Powermover, then it has a push button switch on the handle to activate the receptacle. This button is used to activate the trailer brakes if they are plugged into the standard seven way connector allowing the trailer brakes to stop the load.

MAGNETIC BRAKING ¾ HP PERMANENT MAGNETIC MOTOR (Standard PM5700)

The ¾ hp motor, with its standard hookup, will brake the Powermover, when the speed control is released with a three second delay. There is an emergency button that allows the unit to brake immediately when pushed.

MAGNETIC BRAKING 2HP CONTINUOUS DUTY MOTOR (PM 5900)

The continuous duty motor, with its standard hookup, will brake the Powermover, when the speed control is released with a three second delay. There is an emergency button that allows the unit to brake immediately when pushed.

CHARGING SYSTEM

Your Powermover is equipped with a built-in-charging system. It requires a standard three prong extension cord to use the battery charger. The male end plugs in to a standard 120 volt outlet and the female end plugs into the receptacle located on the right of your Powermover. When your Powermover is not in use you should leave the charger plugged in. When you first plug your charger in you will see a red light come on. This is normal. When the batteries are near a full charge you will see a red and a green light. When the red light goes out and only the green light is on you have reached a full charge. It will not damage the batteries to leave the charger plugged in. You also have a battery level indicator that will show the amount of charge left in your battery. It is located on the handle of your Powermover.

STEERING

Your Powermover is equipped with a steering handle that turns the Powermover when pushed to the right or left. There is a caster under the rear of the PowerMover that swivels as you turn.

CAUTION: WHEN FIRST LEARNING TO OPERATE THE POWERMOVER SLOW AND EASY IS THE BEST POLICY FOR BOTH THE SPEED CONTROL AND THE STEERING CONTROL. USE SLOW SPEED WHEN MAKING TURNS.

HYDRAULIC LIFT

The hydraulic lift option is designed to provide traction for moving heavy objects by transferring some of the weight from the object being moved to the front drive wheels of the Powermover. This transfer of weight is essential to move many of the heavier objects. It also provides a quick way to attach to the load.

HOUR METER

The hour meter is standard equipment on every Powermover as of June 1, 2001. We suggest you keep a log book so you know the proper time to service your Powermover. The hour meter is located in the handle.

OPTIONS

HYDRAULIC LIFT

See paragraph on hydraulic lift.

WEIGHT KIT

Sometimes it is necessary to add weight to move certain loads, especially on non-hydraulic lift models. A variety of weights are available to assist where needed.

FOAM FILLED TIRES

It is highly recommended to foam fill the tires. It adds weight. Allows the tires to carry a heavier load. Prevents flat tires from occurring.

NON MARKING TIRES

Gray non marking tires are available for the Powermover.

ATTACHMENTS

Many jobs require some type of special attachment. We custom make whatever is necessary to do the job. The following standard brackets are available. J-type hooks, pintle hooks, hitch balls, hitch pins, o-rings and saddles. The attachments are adjustable to fit almost any need.

SAFETY SWITCH

The reversing safety switch is located on top of the handle and is designed to activate if you are backing up and it hits your belly. When the switch hits your belly it will depress the switch, which immediately reverses the motor. It is not possible to go backwards when the switch has been activated until you reset the switch. You reset the switch by turning it clockwise. You will hear a click and see the switch pop out to its normal set position. You will now be able to go in reverse.

SAFETY RECOMMENDATION:

IT IS RECOMMENDED THAT WHEN LIFTING A LOAD WITH THE HYDRAULIC LIFT THAT YOU ONLY LIFT IT HIGH ENOUGH TO CLEAR THE GROUND SURFACE AND THEN MOVE THE LOAD. SHOULD YOU FEEL UNCOMFORTABLE WHILE MOVING THE LOAD YOU CAN QUICKLY LOWER IT TO THE GROUND.

GENERAL MAINTENANCE

2 HP MOTOR (PM5900)

CONTINUOUS DUTY: This powerful motor is designed for continuous use. It is a permanent magnet motor and acts as a brake when the speed control is released. Its bearings are factory sealed and require no maintenance; the brushes should be checked every 500 hours of operation.

GREASE FITTINGS

Shafts (grease every 1000 hours of operation)

- 1) 1 at the rear shaft (differential)
- 2) 1 at the front swivel caster (option)
- 3) 1 at the rear steering wheel

BATTERIES

Check the electrolyte level in each of the battery cells to be sure they are ½” above the top of the lead plates. **Caution: Never let the electrolyte drop below the top of the lead plates and never smoke or have an open flame near the batteries. A spark or open flame could cause an explosion causing injury.**

HYDRAULIC FLUID LEVELS (optional)

Check the hydraulic reservoir at least every 150 hours. If it is low bring the level back up to the full mark. Also check the hose and fittings at the same time for any fluid leaks.

CHAINS

Lubricate the chains once every year with motorcycle chain type grease.

TIRES (optional foam filled)

Your Powermover may have foam filled tires. This allows for the tires to carry more weight, adds weight and prevents flat tires.

REPLACING PARTS

RECOMMENDATION

It is recommended that only certified mechanics replace most of the parts on your Powermover.

Ultra-Fab stocks any and all parts necessary to keep your Powermover in good operating condition allowing for the best possible service. Many of the parts are self explanatory and very easy to replace.

The parts breakdown will show you where these parts go but does not explain how to change because it is obvious.

NOTE: SHOULD YOU HAVE ANY QUESTIONS CALL ULTRA-FAB AT 800-860-7571

MOTOR

STEP 1) Open the door to battery compartment and disconnect the negative leads on the battery terminal (2 places) This eliminates all power to the motor and the handle.

STEP 2) Remove the top cover by removing the six screws. Disconnect the two wires from the motor terminals.

STEP 3) Loosen and remove the four bolts on the motor mount plate on the floor of p/m and lift the motor up and out of its location. (The belt will come off the drive sheave as you remove the motor and mount plate).

STEP 4) To reinstall reverse steps 1-3. The mounting plate has adjustments from side to side and well as up and down. Install the motor in a way that the belt tracks true from pulley to pulley, this is achieved with the side to side adjustments, and then adjust the belt tension with the front to back adjustments.

COG TYPE BELT (ON ALL MODELS BUILT AFTER (6/1/05) (Shaft # 1)

A cog type belt is used to drive the power from the motor to a large cog type sheave on the shaft #1. You can replace the belt with out disassembling the unit. To replace the cog belt follow these steps.

STEP 1) Follow the first 2 steps above on replacing the motor.

STEP 2) Release belt tension on the motor. To achieve this loosen the 4 bolts holding the motor mount plate. Allow the motor to slide forward in the elongated slots, this will loosen the belt.

STEP 3) Inside the housing locate the bearing block next to the cog pulley, you will see two (2) set screws, loosen or back off the set screws, DO NOT remove them.

STEP 4) On the outside of the housing (belt side) , remove the access plate (4 5/16 bolts) the bearing block will come off with it.

STEP 5) With the access plate removed you can remove and install a belt with out dismantling the gears and pulleys.

STEP 6) Replace the access plate and tighten up the set screws on the inside bearing block.

STEP S7) Adjust the tension on the belt by pushing the motor back in the elongated slots, this will tighten the belt, secure it to the frame by tightening the 4 bolts. (note check that the belt runs true before replacing covers)

STEP 8) Replace covers

STEP 9) Reconnect batteries

SHAFT 3

STEP 1) Remove the chains, then the 1/2" bolts from side flange bearings. Lift out shaft.

STEP 2) To reinstall, insert shaft and 1/2" bolts but do not tighten. Install the chains, to tighten the chains loosen the lock nut at the adjuster bolt and tighten the adjuster bolt against the bearing block. (move both sides the same to keep the shaft straight in relation with the other shafts) tighten the 1/2" bolts then the lock nuts at the adjustment bolts.

FRONT DRIVE TIRES

To change a tire is just like a car. Remove the lug nuts and the tire and wheel will pull straight out and off.

CHAINS

Adjustment of the chains is accomplished by loosening the bolts securing the bearing block to the frame, and then adjusting the tightening screw. This will push the bearing block and tighten the chain and keep it from moving when you are pulling a heavy load. Once the chains are tensioned lock down the bearing blocks, by securing the bolts. To remove or replace the chain, you must first identify the master link by rotating the chain until you see the master link. Then use needle nose pliers to remove the keeper and pull the chain apart. You can now reverse the steps and put the master link back together.

DIFFERENTIAL (Shaft # 2)

The differential is installed in your Powermover to allow one wheel to stand still or go backwards while the other wheel goes forward during a turn.

Step 1) Remove the chains that go around the sprockets on the shaft. See “chains” above.

Step 2) Remove the 4 bolts that hold both the right and left flange bearings (2 each) and lift the differential out of the main body.

Step 3) Transfer the bearings, sprockets, spacers and lock collars to the new differential shaft making sure they are back in the same order as on the old shaft.

Step 4) Reverse steps 1-4 and make sure all bolts are tight.

HYDRAULIC PUMP

STEP 1) Remove cover top plate.

STEP 2) Disconnect hydraulic hoses (prepare for leakage of hydraulic fluid)

STEP 3) Disconnect wires.

STEP 4) Remove the 2 bolts holding the pump to the main chassis. Easily accessed on the left side of the chassis.

STEP 5) Install new pump and reverse steps 1-4. Then check the hydraulic fluid level in the reservoir to make sure it is at the proper level. There is a line showing where the level should be.

STEP 6) It will be necessary to operate the cylinder all the way up and all the way down to purge the air from the lines. NOTE: You may need to do this procedure more than once to clear the air from the lines.

HYDRAULIC CYLINDER

STEP 1) Remove the pin that holds the shaft of the hydraulic cylinder to the inner mast.

STEP 2) Remove the inner mast by pulling it straight up and out of the outer mast.

STEP 3) Disconnect the upper and lower hoses.

STEP 4) Remove cylinder and replace with new one.

STEP 5) Reverse steps 1-4 and add the proper amount of hydraulic fluid to bring the level up to the full line.

STEP 6) It will be necessary to purge the lines of air. Do this by operating the cylinder to a full up and then down position. You may have to do this procedure more than once to get all the air from the lines.

ULTRA-FAB PRODUCT INC.
PM/5900 HANDLE

ITEM NO.	QTY.	PART NUMBER	DESCRIPTION
1	1	41-010005	HANDLE-LOWER
2	3	41-940601	TERMINAL STRIP
3	1	41-940582	BREAKER-40 AMP
4	1	41-940002	SWITCH-ROCKER
5	1	41-010008	HANDLE-LEFT
6	1	41-010009.001	HANDLE-RIGHT WITH PLUG HOLE MOVED
7	1	41-940538	SWITCH-KEY
8	1	41-141003	THROTTLE-PB6
9	1	41-141038	METER-HOUR
10	1	41-141054	INDICATOR-BATTERY
11	1	41-940502	CHARGER 12 V 20 AMP
12	1	41-940488	COVER-INLET
13	1	41-612416	HANDLE
14	2	41-900239	GRIP-HANDLE
15	1	41-940588	PLUG-BATTERY CONN.
16	1	41-013509	BRACKET-RELAY
17	1	41-940017	RESISTOR
18	1	41-940024	RELAY-TIMER
19	1	41-013508	COVER-RELAY
20	3	41-900244	PLUG-1/2 FINISH
21	1	41-940006	SWITCH-ON/OFF
22	1	17-143097	BOOT SNAP SEAL
23	1	41-001016	BOX-EMERGENCY
24	1	41-940005	SWITCH-EMERGENCY (RED)
25	1	41-001017	COVER-EMERGENCY

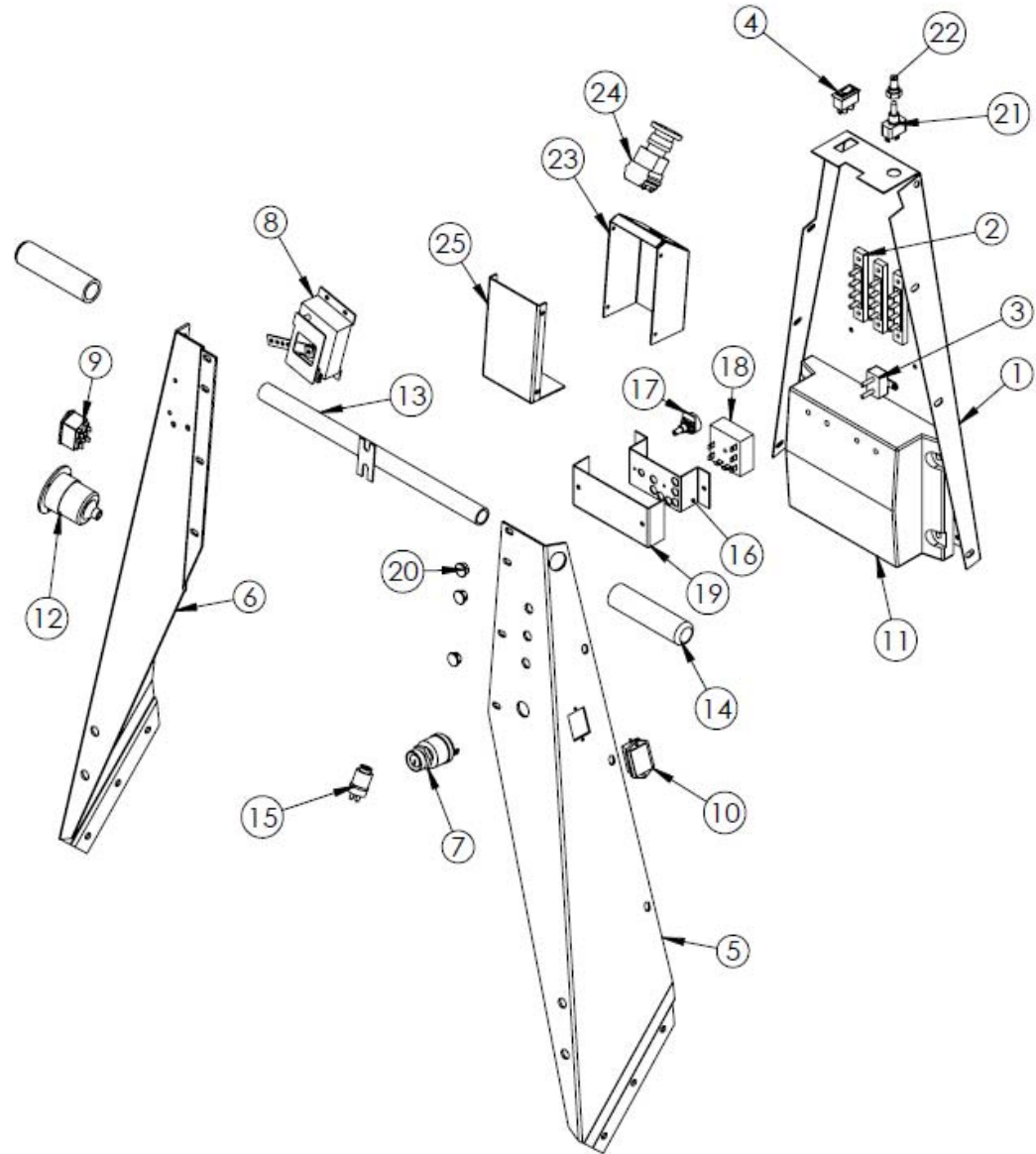

Ultra-Fab Products Inc.
PM5900 Chassis

NO.	QTY.	PART #	DESCRIPTION
1	1	41-612404	FRAME
2	2	SHAFT 4	(SEE BREAKDOWN)
3	2	SHAFT 3	(SEE BREAKDOWN)
4	1	SHAFT 2	(SEE BREAKDOWN)
5	1	SHAFT 1	(SEE BREAKDOWN)
6	1	MOTOR ASSEMBLY	(SEE BREAKDOWN)
7	1	PUMP	PUMP
8	2	41-001001	BATTERY-12 VOLT
9	2	41-940604	6 WAY TERMINAL BLOCK
10	1	41-141039	CONTROLLER-MOTOR
11	1	41-141071	SOLENOID-DC88
12	1	41-940601	TERMINAL STRIP
13	1	41-013521	CLIP-BATTERY
14	1	41-500116	CASTER-6"
15	2	41-500101	TIRE-18"
16	1	41-013657	DOOR-LEFT SIDE
17	1	41-013672	SLOPE PLATE
18	1	41-013502	BALL MOUNT WELDMENT
19	1	41-013670	GEAR COVER
20	1	41-013671	COVER-BATTERY
21	1	41-013669	DOOR-BATTERY
22	1	HANDLE	(SEE BREAKDOWN)

NOTE: ITEM #15 USE 41-500113 NON-MARKING TIRES

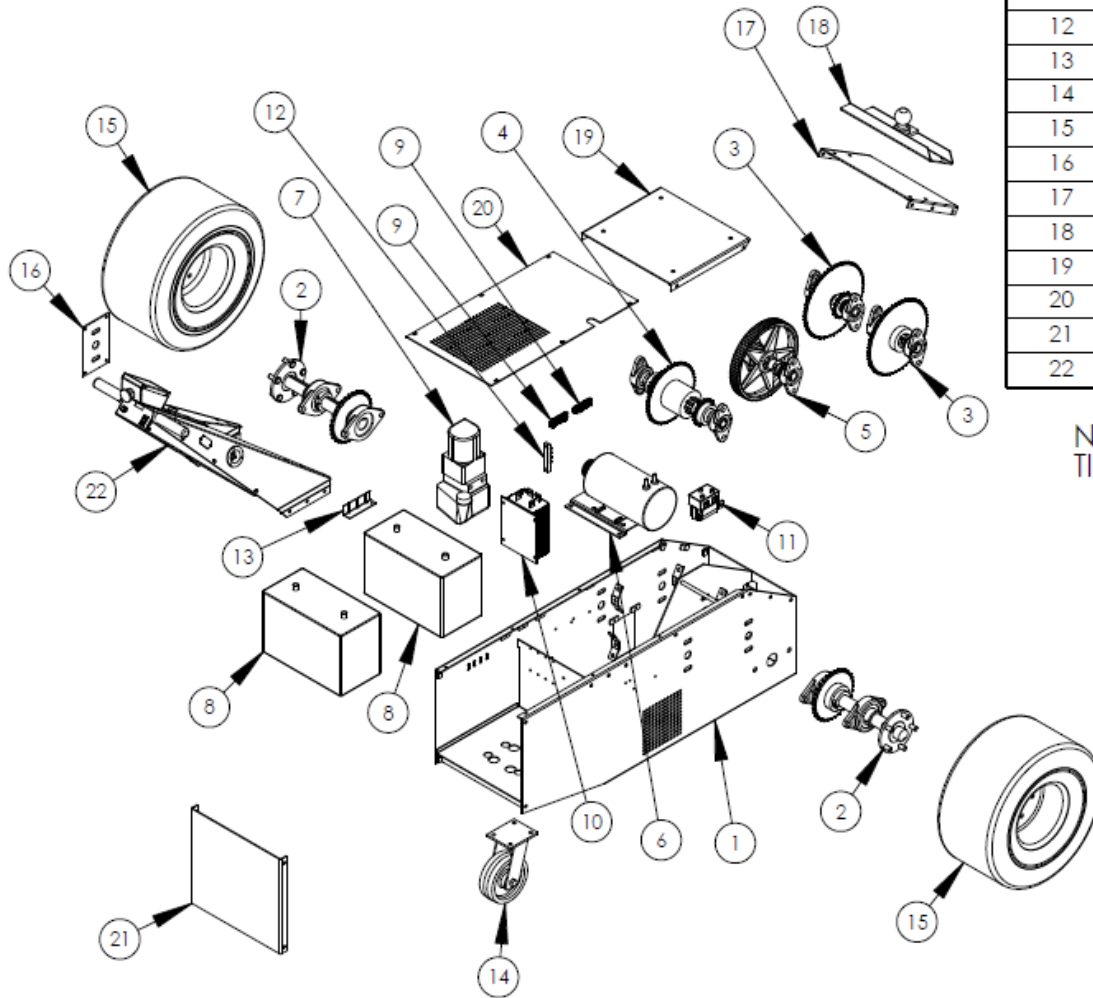

Ultra-Fab Products Inc.
PM5900 SHAFT 1

NO.	QTY.	PART #	DESCRIPTION
1	1	41-070506	SHAFT-SPROCKET
2	2	41-090115	BEARING-SIDE
3	1	41-050114	HUB-SHEAVE
4	1	41-050112	SHEAVE-84T BELT
5	1	41-210005	COLLAR-1" SPLIT
6	1	41-000292	KEY-1/4 X 1 1/8"
7	1	41-210003	COLLAR-1" FULL SPLIT
8	1	41-040162	SPROCKET-40BS12 X 1"
9	1	41-010061	SPACER-15/16"
10	1	41-000293	KEY-1/4 X 3/4"

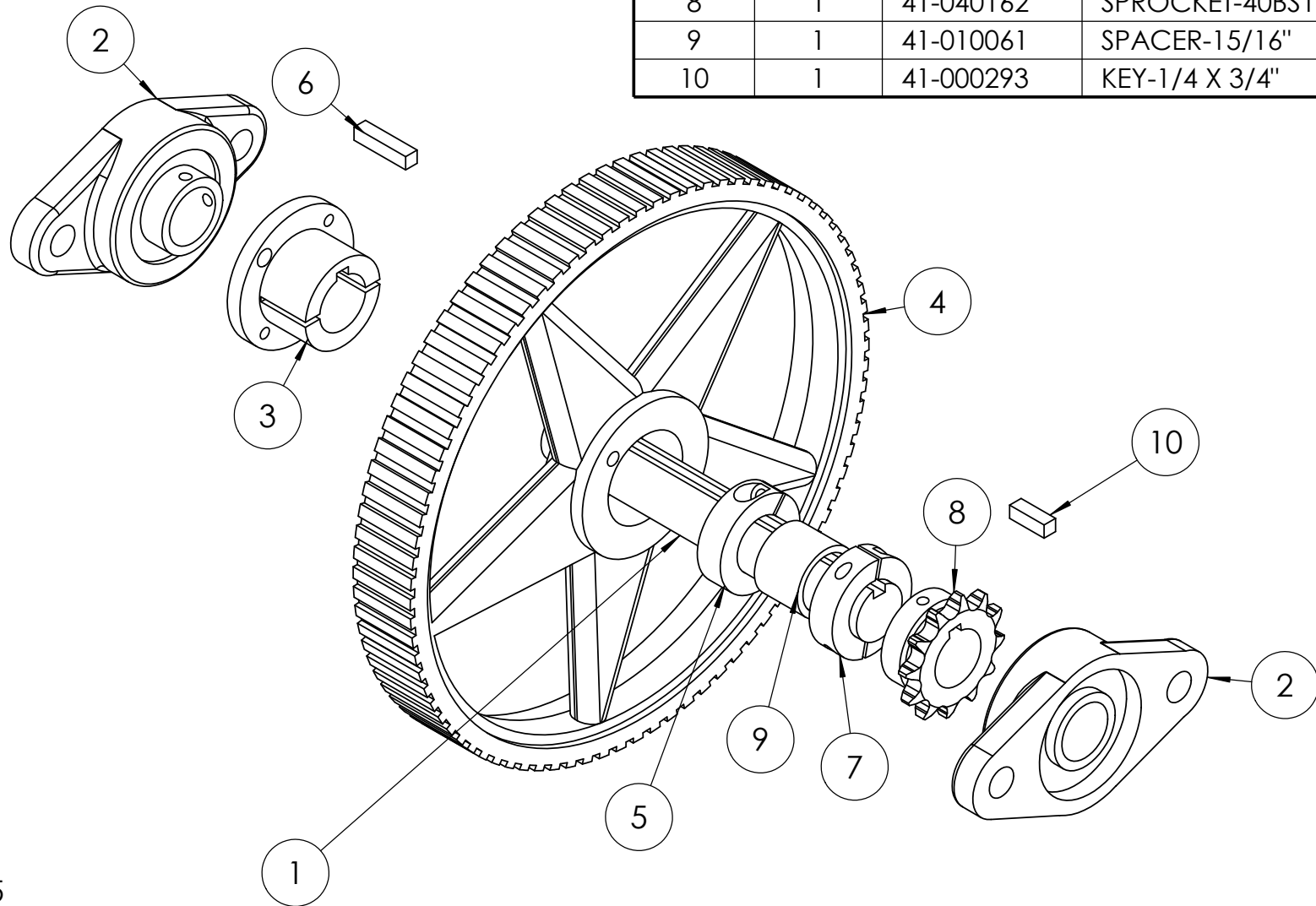

Ultra-Fab Products Inc.
PM5900 SHAFT 2

NO.	QTY.	PART #	DESCRIPTION
1	1	41-001379	DIFFERENTIAL-H.D.
2	2	41-090115	BEARING-SIDE
3	2	41-040177	SPROCKET-40BS20 X 1"
4	2	41-210005	COLLAR-1" SPLIT
5	1	41-040170	SPRCOKET-40A48 W/2.1/8 BORE
6	2	41-000293	KEY-1/4 X 3/4"
7	6	41-030072	WASHER-1.5" X 1" X 10GA.
8	2	41-010052	1/2" SPACER

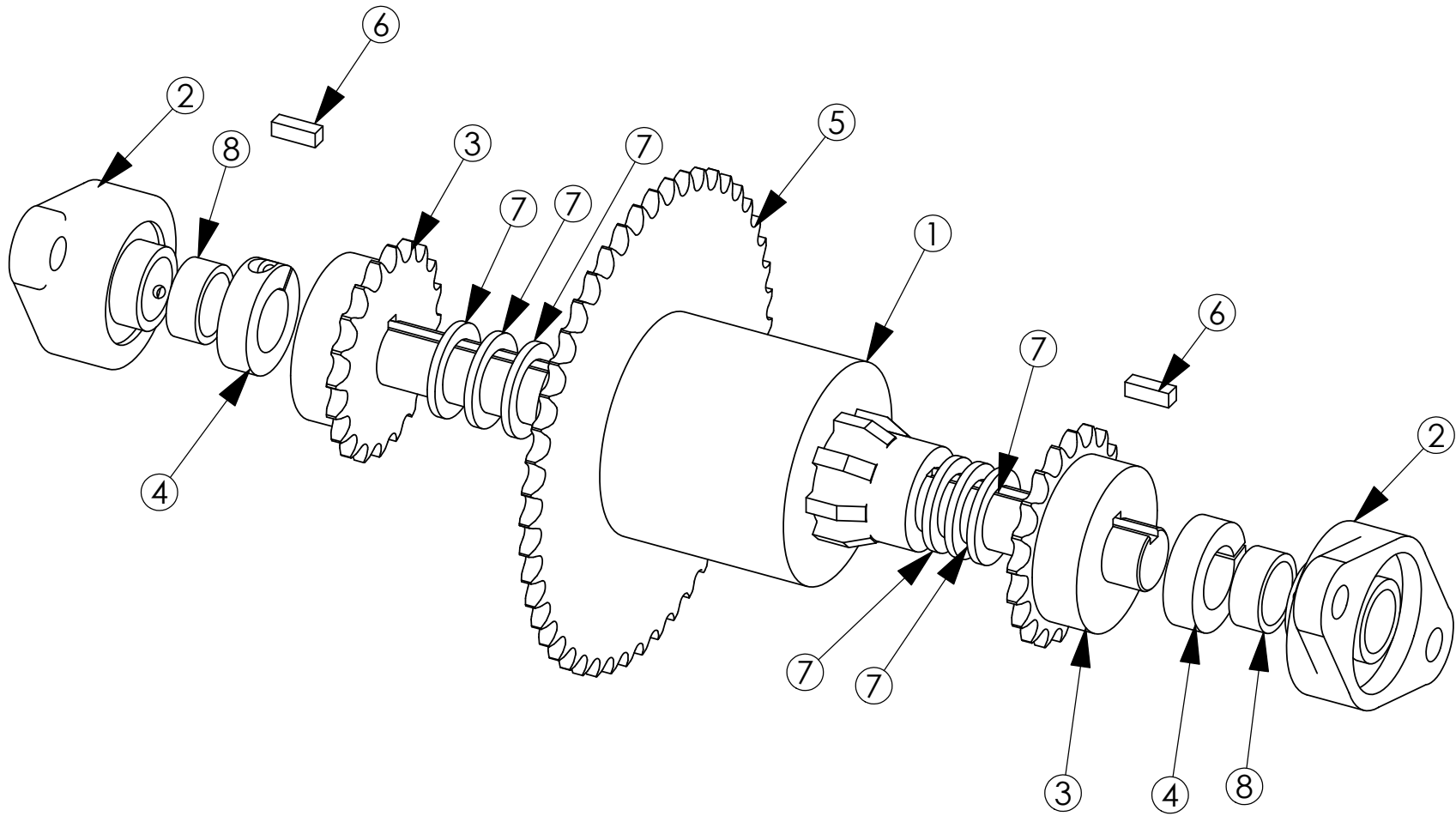

REV 10-05

Ultra-Fab Products Inc.
PM5900 SHAFT 3

NO.	QTY.	PART #	DESCRIPTION
1	1	41-070506	SHAFT-SPROCKET
2	2	41-090115	BEARING-SIDE
3	1	41-040176	SPROCKET-40BS60 X 1"
4	1	41-040175	SPROCKET-50BS15 X 1"
5	1	41-000292	KEY-1/4 X 1 1/8"
6	1	41-000293	KEY-1/4 X 3/4"
7	10	41-030072	WASHER-1.5" X 1" X 10GA.
8	1	41-030071	WASHER-1.5" X 1" X 14GA.
9	1	41-210003	COLLAR-1" FULL SPLIT

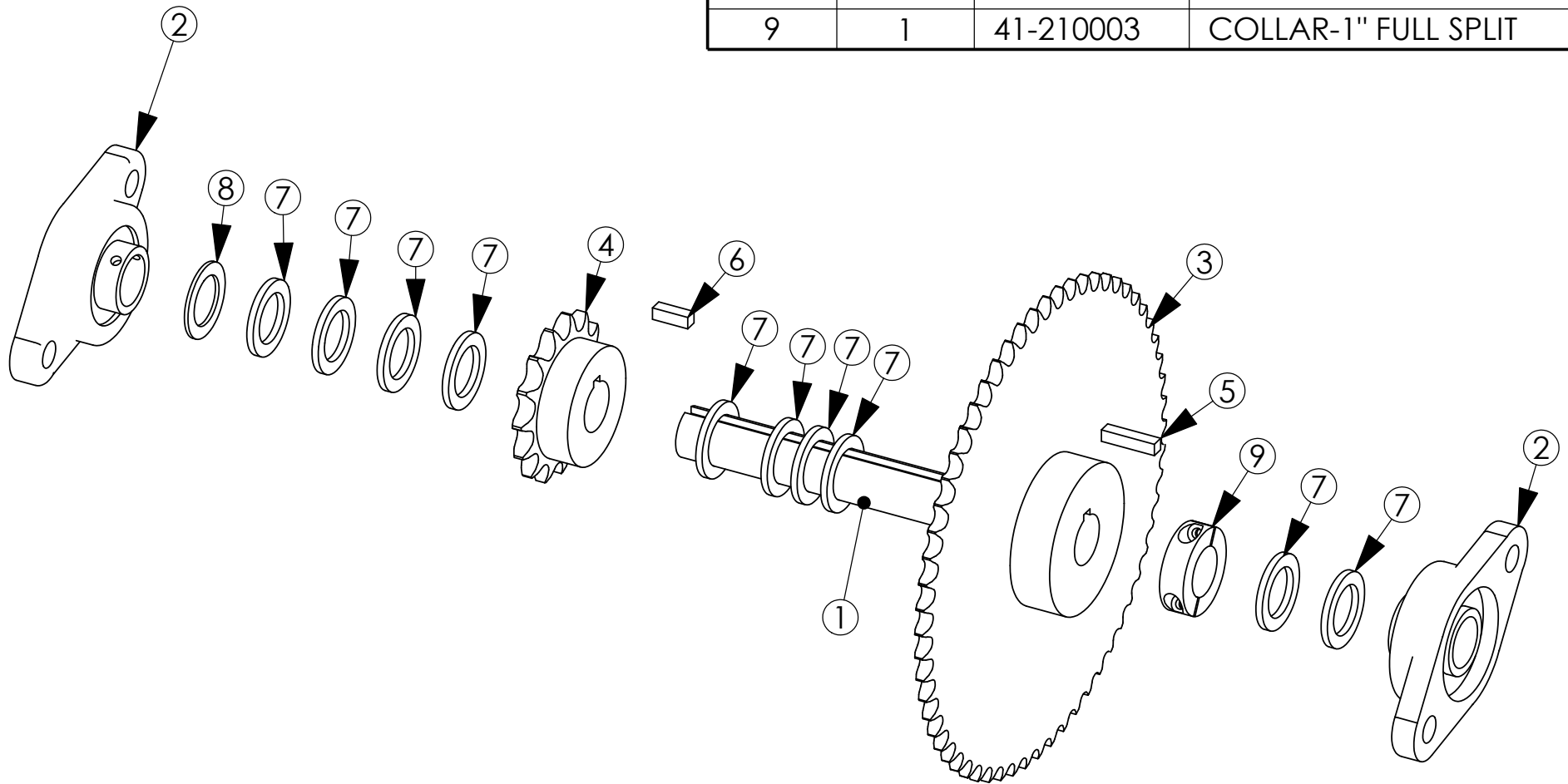

REV 5-05

Ultra-Fab Products Inc.
PM5900 SHAFT 4

NO.	QTY.	PART #	DESCRIPTION
1	1	41-070625	STUBAXLE
2	2	41-090118	BEARING-1 1/2" SIDE
3	1	41-040168	SPROCKET-50BS32 X 1.5"
4	1	41-000295	KEY-3/8 X 1 1/8"
5	2	41-210004	COLLAR-1 1/2" SPLIT

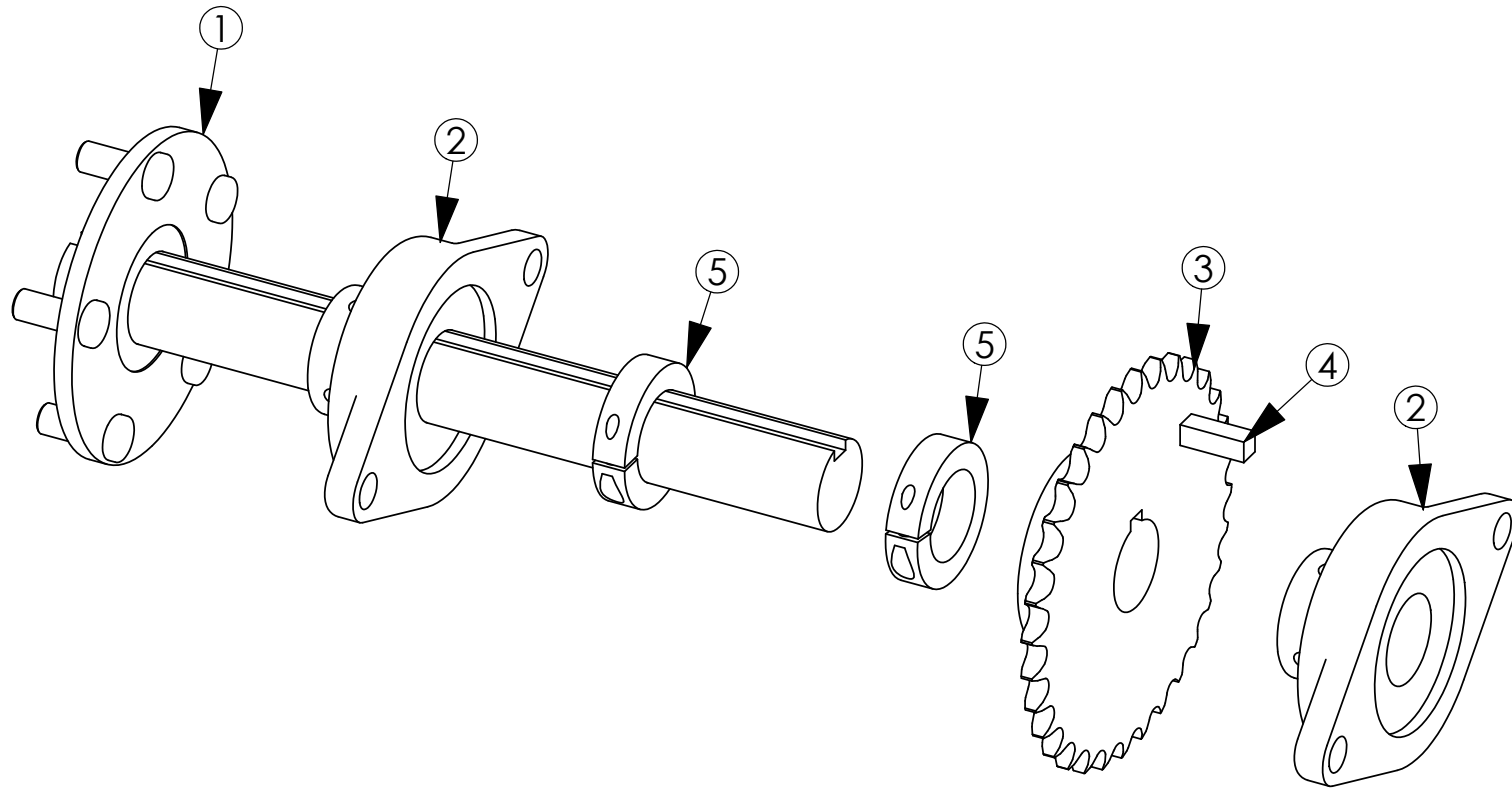

REV 6-05

Ultra-Fab Products Inc.
LIFT ASSEMBLY

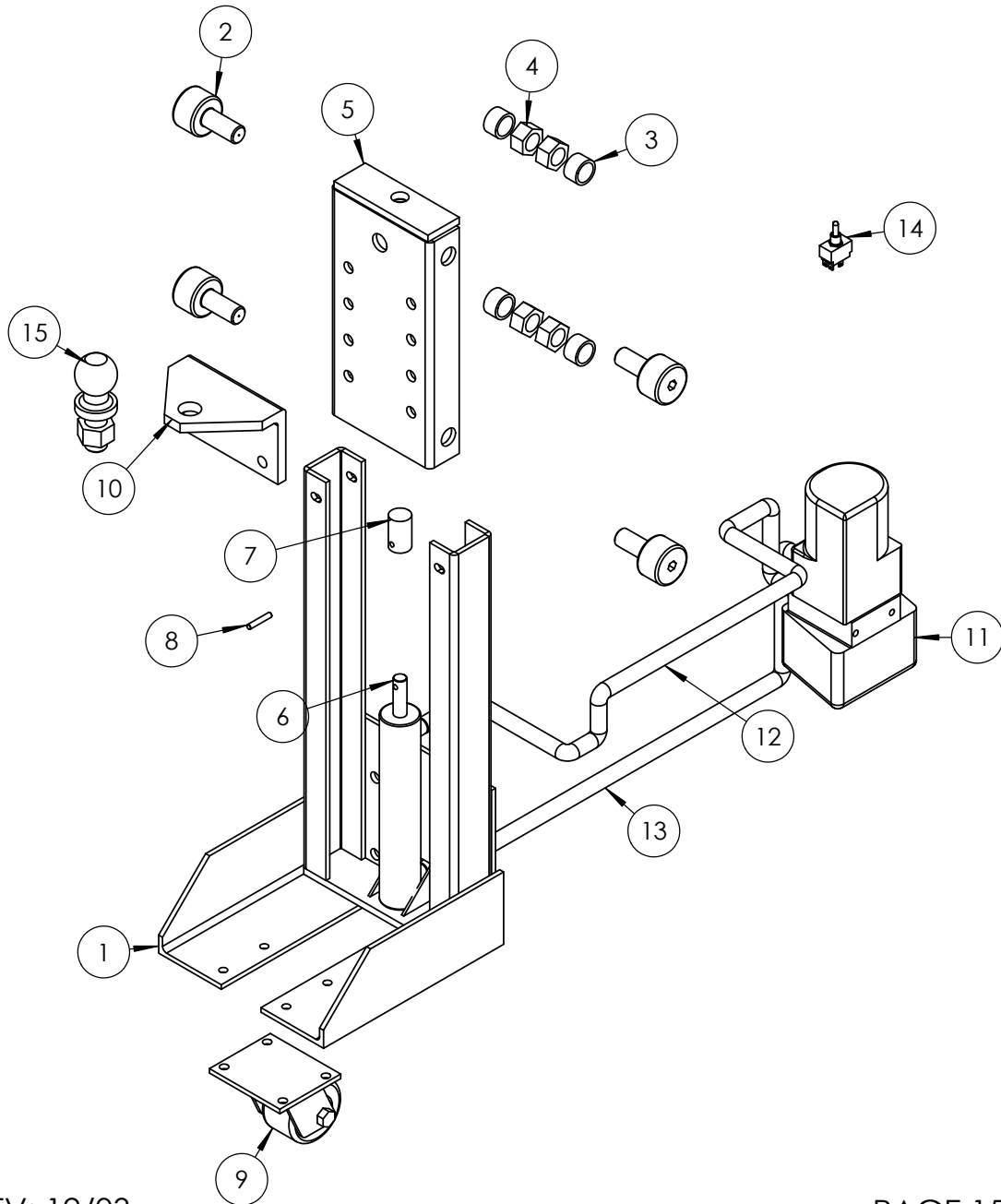

NO.	QTY.	PART NO.	DESCRIPTION
1	1	41-001004	LIFT WELDMENT
2	4	41-141010	CAM-FOLLOWER
3	4	41-010044	SPACER-LIFT
4	4	41-020060	NUT-7/8-14
5	1	41-001005	PLATE-ROLLER
6	1	CYLINDER	CYLINDER-7"
7	1	41-013547	ADAPTER-CYLINDER
8	1	17-741064	PIN-ACME SCREW
9	1	41-500105	CASTER-3"
10	1	41-001006	BRACKET-HITCH B ALL
11	1	PUMP	PUMP
12	1	HOSE #2	HOSE #2
13	1	HOSE #1	HOSE #1
14	1	17-101011	SWITCH-12 VOLT
15	1	41-290157	BALL-HITCH

NOTE: ITEMS (6,11,12,13) PUMP KIT 41-900003

MOTOR ASSEMBLY

NO.	QTY.	PART #	DESCRIPTION
1	1	41-013659	PLATE-MOTOR MOUNT
2	1	41-000688	MOTOR-2 HP. (CONT.)
3	1	41-050113	SHEAVE-15T BELT
4	1	41-000544	KEY-3/16 X 3/4"

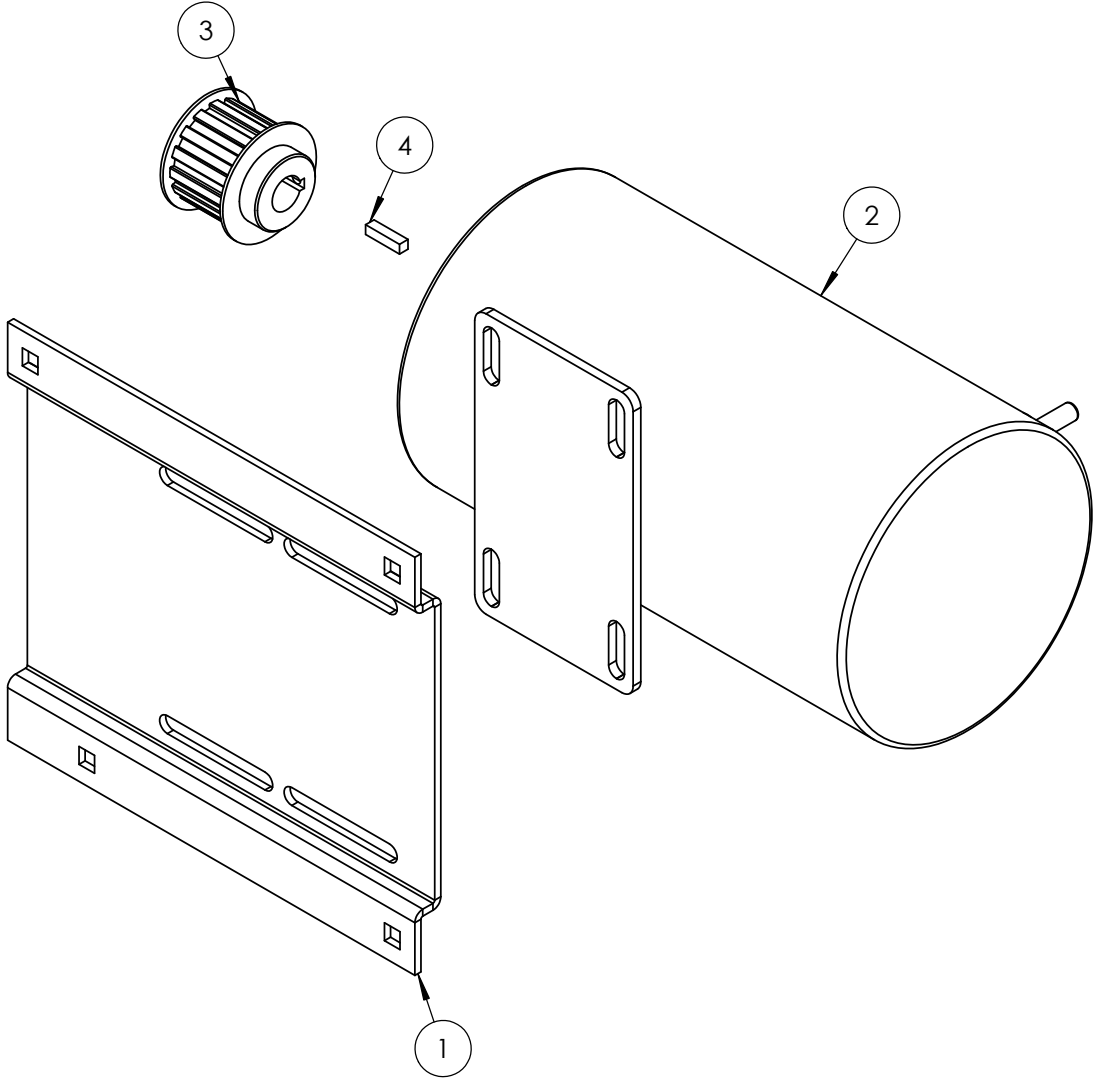

PM5900 Chassis Wiring

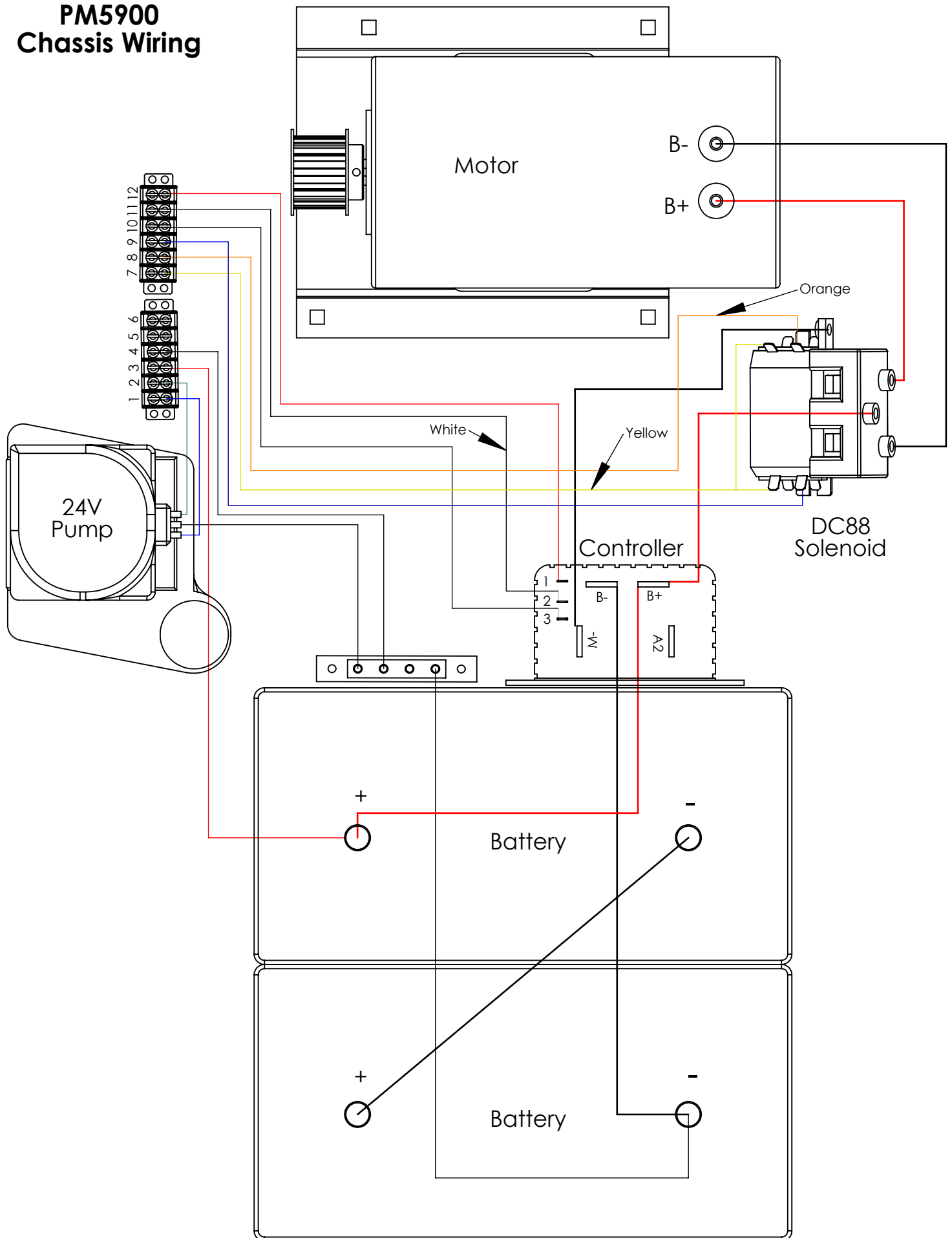

PM5900 Handle Wiring Diagram

