



Ultra-Fab Products, Inc.
57985 State Road 19, South
Elkhart, Indiana 46517

CHOCK & LOCK
TANDEM WHEEL TRAILER CHOCK
21-001060 (Single Pack)
21-001070 (Double Pack)

INSTALLATION INSTRUCTIONS

FUNCTION

The purpose of the Chock & Lock is to enhance trailer occupant comfort by preventing the tandem wheels from moving. When the wheels are chocked, the annoying rocking motion is essentially eliminated.

THINGS TO AVOID



Do not over tighten this wheel chock. Damage can be done to tires or Chock & Lock. This damage is not covered by the warranty. **Do not rely on this Chock & Lock as a brake. While it will assist in braking, other independent devices such as blocks or wedges should also be used.**

OPERATION

As the drawing shows, the Chock & Lock is to be positioned between the tandem wheels at the wheel centerline. It functions by pressing a fixed distance outward (front to back) against the two wheels, locking one wheel to the other. Because of the leverages built into the scissors mechanism and the over-center cam in the handle, modest operator effort develops tremendous force at the wheels. In normal use, the operating handle will swing through approximately a 90 degree vertical arc and stay in the "locked" (down) position by itself. The padlock hole is provided to allow for the utilization of a padlock to discourage theft of the trailer or wheel chock.

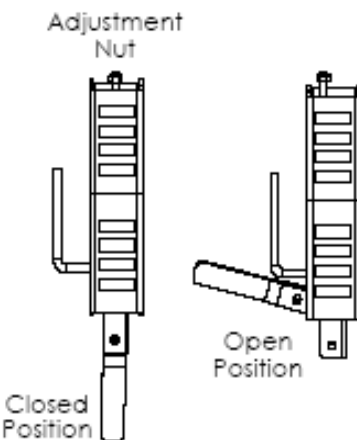
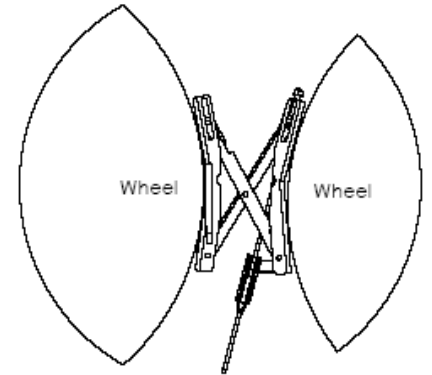

ADJUSTMENT

Your Chock & Lock is precisely adjustable for tandem wheel spacing from approximately 1½" – 5¼". The adjustment is accomplished by turning the nut on the threaded rod protruding from the top of the unit. As it is shipped, the unit is in its narrowest position and will not function. To adjust the width the first step is to pull the unit apart (wider). The threaded rod will then protrude further, exposing more threads below the nut. Turn the nut clockwise and note that this changes the operating width of the unit. Adjust until the chock will fit closely between the two wheels with the handle in the open position (perpendicular to the "shoes"). With the unit properly adjusted, it will function every time by only moving the handle through its arc. Trailer size and geometry will influence how tight the chock must be to work well. With experimentation, you may determine that a lighter setting, which requires less operator effort, is suitable.

STIFFNESS

A new unit may be a little stiff in movement. Working it open and closed over its range a few times will normally correct this.

TIRES

The performance of the chock & Lock is dependent on proper trailer tire pressures. Check tire pressures frequently for safety, good tire wear and good chock performance.

SERVICE

There is no specific service required of your Chock & Lock. A little light lubricant on the pivots from time to time will enhance useful life.

WARRANTY

ULTRA-FAB PRODUCTS, INC. warrants that this product will be free from defects in material and workmanship for the lifetime of the original purchaser. Should a failure to conform to this warranty appear, ULTRA-FAB PRODUCTS, INC. shall, upon notification thereof, and proof of purchase, correct such non-conformity, at our option, by repair or replacement FOB factory of the defective parts.

LIMITATION OF LIABILITY

Neither party shall be liable for special, indirect, incidental or consequential damages. The remedies of the purchaser, as set forth herein, are exclusive, and the liability of ULTRA-FAB PRODUCTS, INC. shall not exceed the price of the equipment or part on which such liability is based.