

## INSTALLATION/OPERATION

### ULTRA 5<sup>th</sup> WHEEL LANDING GEAR

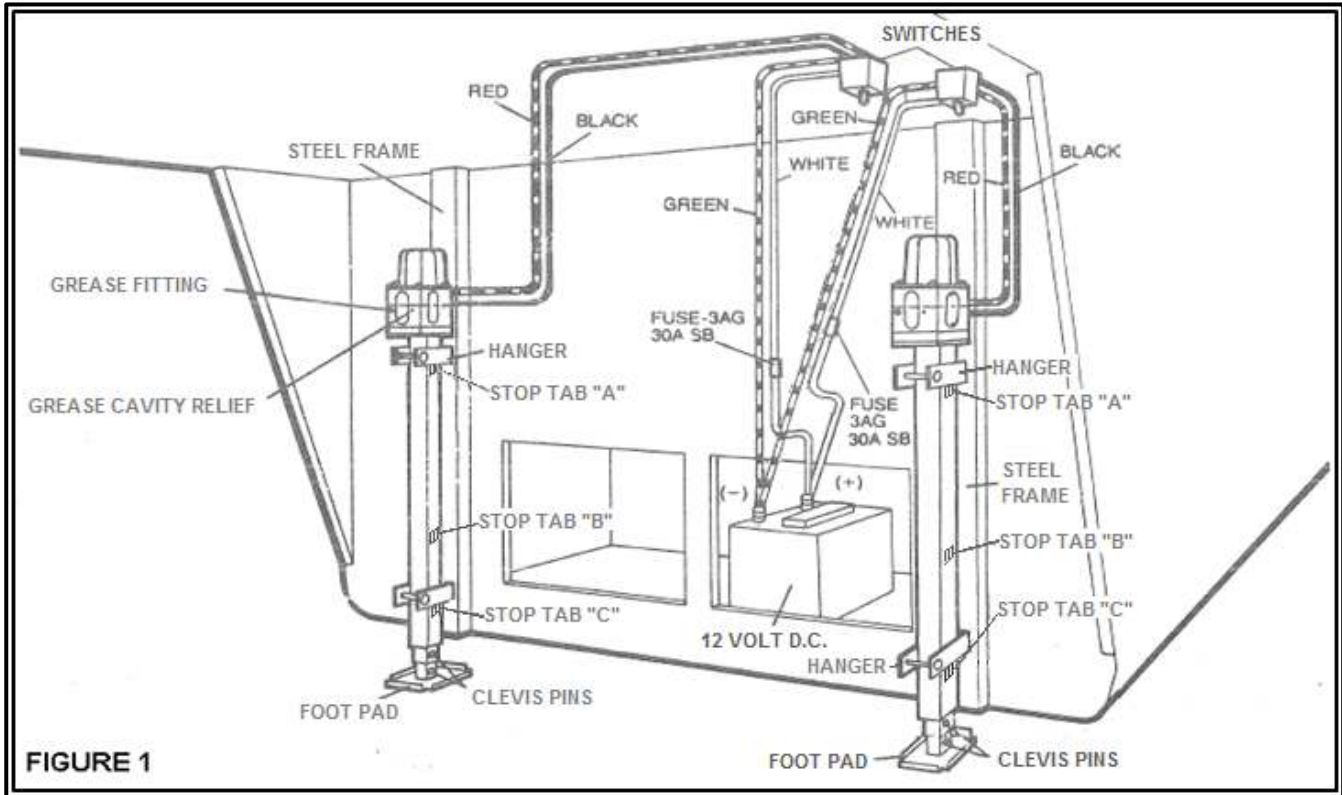

## APPLICATION

The Ultra 5<sup>th</sup> Wheel Landing Gear is designed and intended for use on all 5<sup>th</sup> Wheel Trailers. The entire trailer can be leveled easily and quickly when the Ultra-Fab PowerTwin II is added to the rear of the trailer. See your Ultra-Fab dealer for more information.

*Ultra-Fab Products reserves the right to modify appearances and specifications without notice.*

## INSTALLATION

### TOOLS REQUIRED FOR INSTALLATION

- Pencil
- Measuring Tape
- Pliers or Wire Crimpers
- Wrenches or Socket Set
- Wire Cutters

## SPECIFICATIONS

Lifting Capacity – 6,000 lbs. per jack leg

Stroke – 21"

Extended Length – 74"

Retracted Length – 36"

Area of Foot Pad – 22 sq. in.

Max. Adjustment of Foot Pad – 17"

Power Requirement – 12 Volts D.C.

**IMPORTANT:** Read ALL of the following steps before beginning installation.

**NOTE:** The front end of the trailer should be raised up and supported at a comfortable working height. Remove existing landing gear, if any. The Ultra-Fab 5<sup>th</sup> Wheel Landing Gear hangers should be welded on. Use of existing hangers is acceptable if located properly.



57985 State Road 19, South  
Elkhart, Indiana 46517  
PH (574) 294-7571  
FX (574) 294-4980  
www.ultra-fab.com

## ULTRA 5<sup>th</sup> WHEEL LANDING GEAR

p/n 17-943010

US PATENT 9,821,774 B1

### MOUNTING THE HANGERS (replacing)

- If you are replacing a manual or single motor set of landing legs, measure the hangers. Compare this measurement to the figure to the right.
  - If the measurement is **13.5 inches** you can use your stock hangers and will use stop tab **A & B** on the figure to the right.
  - If the measurement is **19.125 inches** you can use your stock hangers and will use stop tab **A & C** on the figure to the right.
- Slide the leg into hanger with stop tab below both hangers and install 3/8" carriage bolts. **FIGURE 1** (front page).

**NOTE: The two hangers can only be positioned ABOVE stop tabs A & B or A & C, never B & C.**

### MOUNTING THE HANGERS (new installation)

- Determine exact locations for Ultra-Fab 5<sup>th</sup> Wheel Landing Gear. The top and bottom clamping hangers for each leg must be mounted against steel members for secure mounting.
- Position each landing leg so that the uppermost clevis pin falls just below the bottom of the trailer. This is to permit easy adjustment of the foot pad.
- Mark the exact location for mounting each set of hangers, making sure that the landing legs are at the same height and that they are straight vertically. **FIGURE 1.**

**NOTE: The two hangers can only be positioned ABOVE stop tabs A & B or A & C, never B & C.**

- Weld the hangers. **TIP:** Install the hanger onto the landing legs then using a 12V battery or other power source, extend the legs to the proper height. Position the legs against the frame member of the trailer. Tack weld hanger to frame, if needed remove leg and finish welding. Next, secure each leg to the clamping hangers, using a set of 3/8" x 3 1/2" carriage bolts, washers and nuts.

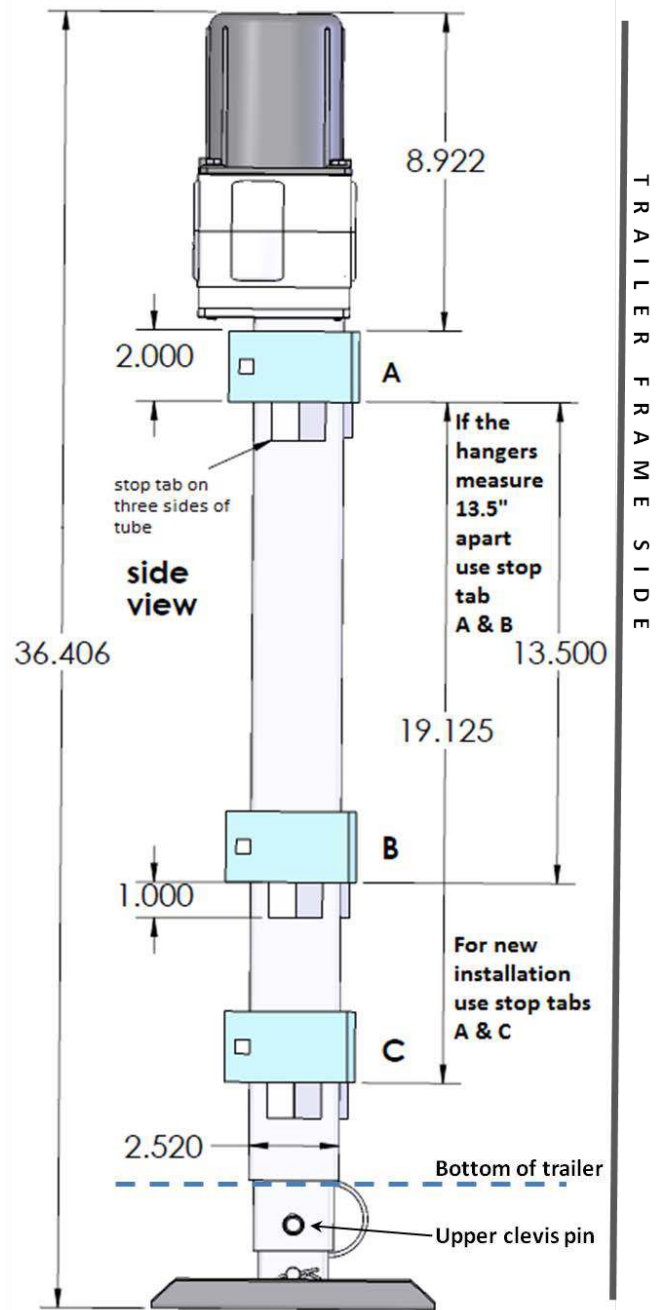

### INSTALLING THE SWITCHES

- Install the two switches. The weather-proof switches can be mounted at any desired location. However, the most practical place might be under the trailer overhang. While inconspicuous, this location allows good view of the levelers and hitching mechanisms.
- Place the switch within the cover, place the gasket between the cover and the mounting surface, and secure with four screws (NOT provided). **FIGURE 2.**

**NOTE: the two switches may be installed in the truck's cab and connected to the levelers with a 4-prong connector.**

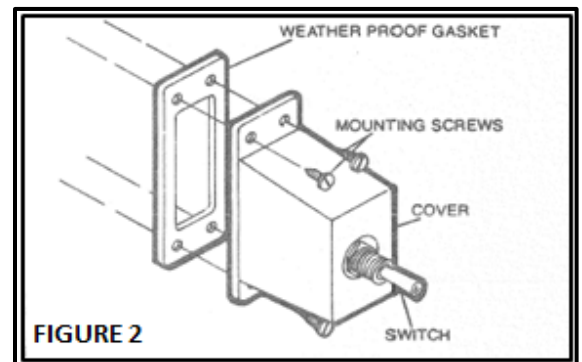



57985 State Road 19, South  
Elkhart, Indiana 46517  
PH (574) 294-7571  
FX (574) 294-4980  
www.ultra-fab.com

## ULTRA 5<sup>th</sup> WHEEL LANDING GEAR

p/n 17-943010

US PATENT 9,821,774 B1

### WIRING THE SYSTEM

1. Wire the Ultra-Fab 5<sup>th</sup> Wheel Landing System. **FIGURE 1.**

**CAUTION: To avoid short circuits, leave the fuse out of the fuse holder until wiring is completed.**

**WARNING: Use of wire smaller than #10 gauge for extensions will void the warranty, if more than the provided amount of wire is needed, be sure to use #10 or larger gauge wire.**

**NOTE: Join all wires with solder and electrical tape or crimp-type connectors. Do NOT use wire nuts as they tend to loosen and fall off, as well as providing no protection to the copper wires from corrosion.**

2. Connect the GREEN wire to the negative terminal of the battery, or securely ground it to a clean, paint-free spot on chassis.
3. Connect the Fuse Holder to the positive post of battery and then to the WHITE wire from switch.
4. Connect the RED wire from switch to RED wire from motor.
5. Connect the BLACK wire from switch to BLACK wire from motor.
6. Test the Ultra-Fab 5<sup>th</sup> Wheel Landing Gear. Replace the fuse (3AG 30amp Slow Blow) and test the landing legs one at a time. Check to see that the switches are wired in a logical relationship to the landing legs and to each other.

## OPERATION

### TO EXTEND

1. Choose a location as level as possible, to minimize the need for leveling and stabilizing.
2. Place blocks in front of and behind each wheel.
3. Disconnect the upper clevis pins, lower the foot pads to the ground, and replace the pins into the nearest hole.
4. To raise the trailer from the truck, both switches can be operated at once.
5. Because they are independently controlled, the 5<sup>th</sup> Wheel Landing Gear can be used to level the trailer, as well as to hitch and unhitch.

### TO RETRACT

1. Position the truck to align hitching mechanisms.
2. Operate the two switches to lower the trailer and couple it onto the truck. Continue retracting the landing legs until they are fully retracted.
3. Remove clevis pins, slide foot pads up all the way and secure by replacing the pins.

**NOTE: All levelers should be cycled at least once a month.**

## MAINTENANCE

### LUBRICATION

**WARNING: DO NOT USE pneumatic-powered lube equipment as it can damage the landing gear. Use hand-operated grease gun only. We recommend MOLY BENTONE GRADE 3 GREASE for both the MOTOR/GEAR ASSEMBLY and LOWER STEM.**

1. The **MOTOR/GEAR ASSEMBLY** should be greased annually through the grease fitting. Two (2) pumps from a

grease gun is all that should be necessary. Wipe off excess grease. **DO NOT OVER GREASE.**

2. The jack **LOWER STEM** should be greased annually through the grease fitting. Lower the rubber band on the outer tube to expose the grease fitting access hole. Extend the leg until the grease fitting is centered in the hole. Apply two (2) pumps of grease and cover the access hole with the rubber band.



57985 State Road 19, South  
Elkhart, Indiana 46517  
PH (574) 294-7571  
FX (574) 294-4980  
www.ultra-fab.com

# ULTRA 5<sup>th</sup> WHEEL LANDING GEAR

p/n 17-943010

US PATENT 9,821,774 B1

| ITEM NO. | QTY. | PART NUMBER   | DESCRIPTION               |
|----------|------|---------------|---------------------------|
| 1        | 1    | 17-766004     | LOWER STEM ASSEMBLY       |
| 2        | 1    | 17-750007.003 | MOTOR/GEAR ASSEMBLY       |
| 3        | 1    | 17-741622     | COVER-MOTOR               |
| 4        | 1    | 17-141006.003 | GASKET                    |
| 5        | 4    | 39-113369     | BOLT M6X110               |
| 6        | 2    | 17-741439     | HANGER                    |
| 7        | 2    | 17-113360     | BOLT-3/8-16X3.5" CARRIAGE |
| 8        | 2    | 17-113107     | WASHER 3/8" LOCK          |
| 9        | 2    | 17-113105     | NUT 3/8-16                |

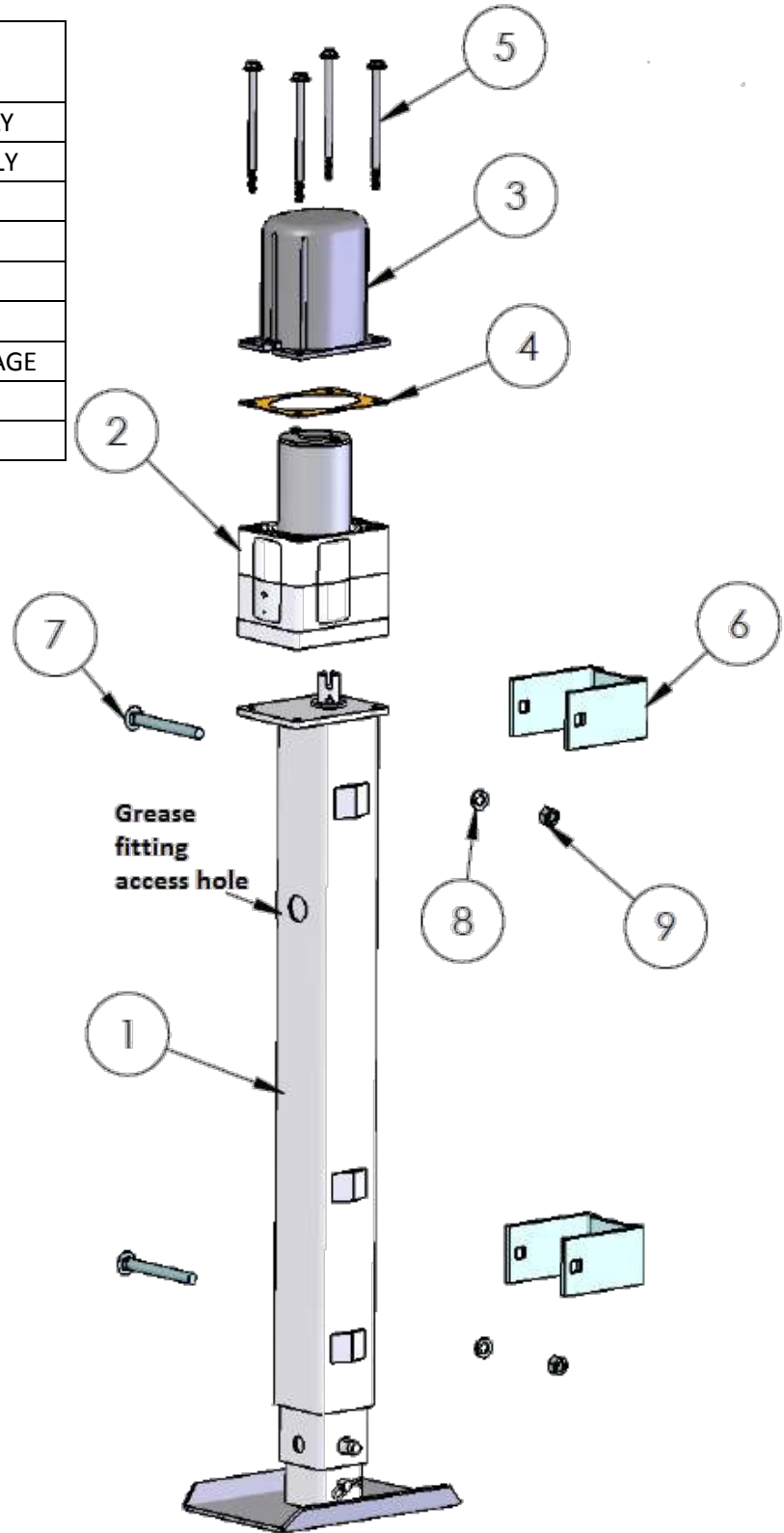

## HELPFUL HINTS

1. On softer ground use larger pads under the foot pads.
2. Although the Ultra-Fab 5<sup>th</sup> Wheel Landing Gear are of extra-sturdy construction, care should be taken not to back the truck into the levelers.
3. In case of a power failure malfunction, the landing gear can be operated manually by removing the four (4) screws that hold the motor/gear assembly. The slotted shaft can then be turned with a large flathead screwdriver. When replacing motor, mesh the assembly into the slotted shaft, then rotate assembly to align the screws with their respective holes.



57985 State Road 19, South  
Elkhart, Indiana 46517  
PH (574) 294-7571  
FX (574) 294-4980  
www.ultra-fab.com

**ULTRA 5<sup>th</sup> WHEEL LANDING GEAR**  
**p/n 17-943010**

US PATENT 9,821,774 B1



**Ultra-Fab Products, Inc.**

**THREE-YEAR LIMITED WARRANTY**

**DELUXE 5<sup>TH</sup> WHEEL LANDING GEAR, ULTRA SWAY CONTROL, WEIGHT DISTRIBUTION HITCH, BALL MOUNTS, HITCH BALLS, POWERTWIN II STABILIZERS, THE ELIMINATOR STABILIZER, LEVELING BLOCKS AND MANUAL TONGUE JACKS**

**THE MANUFACTURER NAMED BELOW MAKES THE FOLLOWING WARRANTY WITH RESPECT TO THE ABOVE ULTRA-FAB PRODUCTS**

1. This Warranty is made only to the first Purchaser (hereinafter called the "Original Purchaser") who acquires this product for their own use.
2. This Warranty will be in effect for three years from the date of purchase by the Original Purchaser. It is suggested that the Original Purchaser retain a copy of the dated bill of sale as proof of the date of purchase.
3. This Warranty covers only specified parts which shall be free from defects in material and workmanship under normal use. This Warranty does not cover conditions unrelated to the material and workmanship of the product. Such unrelated conditions include, but are not limited to (a) faulty installation and any damage resulting from such; (b) the need for normal maintenance and any damage resulting from the failure to provide such maintenance; (c) failure to follow Manufacturer's instructions for use of this product, and (d) any accident to, or misuse of, any part of this product and any alteration by anyone other than the Manufacturer or its authorized representative.
4. In order to obtain the benefits of this Warranty, you should return the product which you find defective to the Manufacturer named below during the period that this Warranty is in effect. All charges incurred in delivery of the product to the Manufacturer, and in picking it up after the Warranty service has been completed, must be paid by the Original Purchaser.
5. Any item returned in the manner described in paragraph 4 will be examined by the Manufacturer. If it is found that the returned item was defective in material or workmanship, the Manufacturer will repair it without charge for material and labor.
6. Ultra-Fab will pay freight on replacement parts during the first 90 days of ownership by the Original Purchaser.
7. The Manufacturer does not authorize any person or company to create any Warranty obligation or liability on their behalf.
8. IN NO EVENT SHALL THE MANUFACTURER BE LIABLE FOR INCIDENTAL OR CONSEQUENTIAL DAMAGES. SOME STATES DO NOT ALLOW THE EXCLUSION OR LIMITATION OF INCIDENTAL OR CONSEQUENTIAL DAMAGES SO THE ABOVE LIMITATION OR EXCLUSION MAY NOT APPLY TO YOU.
9. ANY IMPLIED WARRANTY, INCLUDING THE IMPLIED WARRANTY OF MERCHANTABILITY AND FITNESS FOR ANY PURPOSE, IS LIMITED TO THE DURATION OF THIS LIMITED WARRANTY. SOME STATES DO NOT ALLOW LIMITATIONS ON HOW LONG AN IMPLIED WARRANTY LASTS, SO THE ABOVE LIMITATION MAY NOT APPLY TO YOU.
10. THIS WARRANTY GIVES YOU SPECIFIC LEGAL RIGHTS, AND YOU MAY ALSO HAVE OTHER RIGHTS WHICH VARY FROM STATE TO STATE.

**Ultra-Fab Products, Inc.**

57985 SR 19 S., Elkhart, IN 46517  
Tel: (574) 294-7571 Fax: (574) 294-4980  
[www.ultra-fab.com](http://www.ultra-fab.com)

**REGISTER  
YOUR PRODUCT**

Please visit our website [www.ultra-fab.com](http://www.ultra-fab.com)  
click on the **WARRANTY** tab and select **REGISTER YOUR WARRANTY**.

**As a registered ULTRA-FAB customer, you'll be able to:**  
• Stay informed of new products, announcements, and special offers.  
• Get faster updates and news by including your email address.