

INSTALLATION/OPERATION

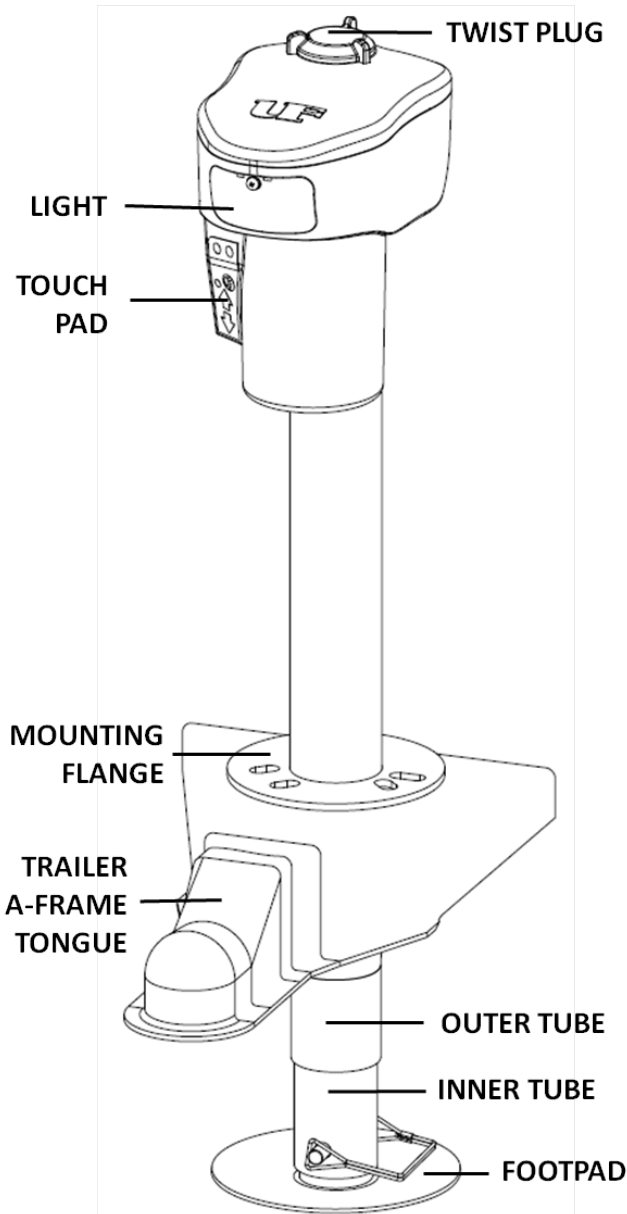

Travel – 21"

Power Requirement - 12V DC.

Outer Tube OD - 2¹/₄"

Inner Tube OD - 2"

Retracted Height - 33"

Removable Foot Pad - 7" dia. (Adjustable)

Approximate Shipping Weight – 28 lbs.

INSTALLATION

1. Block the wheels and support the trailer "A" frame securely.
2. Remove the existing jack.

NOTE: Save the original nuts, bolts, and washers that came with the jack you are replacing for installing the Phoenix 5500 Electric Tongue Jack.

3. Install the Electric Tongue Jack using original nuts and bolts. Depending on user's personal preference, align the motor head so that the motor housing is facing the front of the "A" frame or so that the motor housing is facing the driver side of the trailer.
4. The Electric Tongue Jack was designed to replace an existing manual jack. The diameter of the outer tube of your chosen jack, will need to match the existing hole size, or you will need to modify the hole diameter to fit.
5. Install Fuse Holder. By cutting the RED wire loop, then either crimping or soldering the connections, attach one end to the positive post of the trailer battery. The other end of the fuse holder's RED wire will be connected to the RED wire from the jack. This RED wire provides 12V power to jack.
6. Connect the RED positive lead to the positive terminal of the battery. Connect the BLACK ground wire to negative terminal of the battery.

APPLICATION

The Phoenix 5500 Electric Tongue Jack is a 12-volt motor-driven ball-screw jack for use on travel trailers, boat trailers, and cargo trailers.

SPECIFICATIONS

Vertical Load – 5500 lbs. continuous over full stroke with 6000 lbs. instantaneous tongue breakaway capacity.

INSTALLATION/OPERATION

WARNING



When using an extension wire, **DO NOT** use smaller than #10 gauge wire.

CAUTION



We do not recommend using the flip-up type footpad. Doing so requires the tongue jack to be altered which voids the warranty and can cause the failure of the jack.

OPERATION

1. Block trailer wheels securely.
2. The Phoenix 5500 Electric Tongue Jack is operated by means of the touch pad located next to the motor housing.
3. To extend jack, push & hold Extend Button.
4. To retract jack, push & hold Retract Button.
5. The GREEN light should turn on and remain on while jack is in Extend/Retract operation.
6. If a steady RED light comes on in Extend/Retract operation, a low voltage situation exists and the battery needs to be fully charged.
7. If the RED light flashes quickly for three (3) seconds, a high amp situation exists and jack will turn off after three (3) seconds. The jack will reset itself in five (5) seconds and can be used again until a high amp situation occurs.
 - A. The high amp draw situation can be caused by too much load. Reduce the tongue weight of the trailer.
 - B. The high amp draw can also be caused by worn parts and the jack needs to be serviced and owner should call Ultra-Fab for service options.

AUTO-EXTEND & AUTO-RETRACT

The Phoenix 5500 Electric Tongue Jack has two new features; Auto-Extend and Auto-Retract.

AUTO-EXTEND: Allows user to extend the jack leg to the ground without having to continually press and hold the Extend button. This is especially helpful when detaching RV from tow vehicle.

1. Initiate Auto-Extend by pressing the Extend Button quickly two times. The jack will extend to the ground and stop.
2. For whatever reason, the Auto-Extend can be cancelled by pressing any other button.

AUTO-RETRACT: Allows user to retract jack leg without having to press and hold the Retract button. This is especially helpful when user wants to attach RV to tow vehicle.

1. Initiate Auto-Retract by pressing the Retract Button quickly two times. The jack will retract to the top limit and stop.
2. For whatever reason, the Auto-Retract can be cancelled by pressing any other button.

MANUAL OPERATION

1. Disconnect the fuse. (unscrew and pull apart)
2. Remove twist plug in the access hole. (located top center of the housing cover)
3. Insert the supplied $\frac{9}{16}$ " socket in the access hole, over the drive hex head. Using your own socket handle, rotate the socket clockwise to retract and counter clockwise to extend.
4. When complete, remove socket and replace twist plug, and reassemble the fuse connection.

IMPORTANT: Recalibration must be performed before resuming normal operation. Or damage could result.

CALIBRATION METHOD TO SET TRAVEL LIMITS

The jack is calibrated at the factory and is ready for use when taken out of the box. **IF THE JACK HAS BEEN MANUALLY OPERATED, SERVICED OR IF THE JACK IS SUSPECTED TO BE OUT OF CALIBRATION FOR WHATEVER REASON, THEN USER SHOULD RECALIBRATE THE TRAVEL LIMITS.** To calibrate the travel limits of the jack, follow these steps:

1. Press and hold Extend/Retract button for three (3) seconds and GREEN light will flash three (3) times indicating both buttons are pushed.
2. After three (3) seconds the WHITE light will flash indicating the jack is in calibration mode. Press Extend or Retract button so that the end of the outer tube is located on the top edge of the calibration hole (see parts list view).
3. Press and hold LIGHT button until WHITE light goes off indicating that the jack is now calibrated. After the white light goes off, the jack will immediately move (up or down about $\frac{3}{8}$ "") to set the location sensor. The calibration hole should not be visible after the location sensor has set.
4. Jack is now ready to use by pushing Extend or Retract buttons.

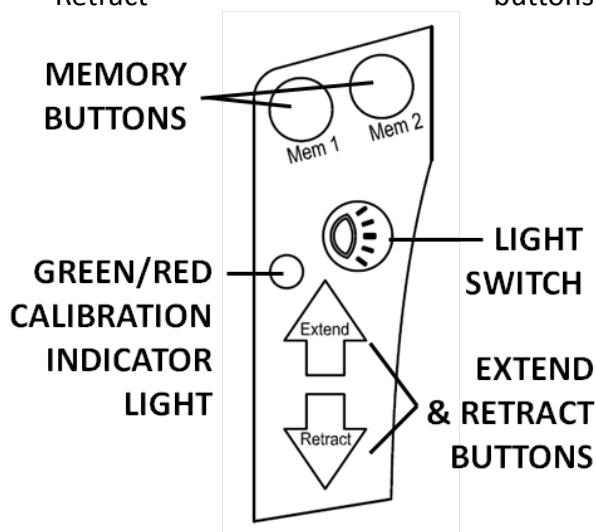

TWO MEMORY BUTTONS

(Mem 1 & Mem 2)

These can be used to remember certain height locations such as hooking and unhooking from tow vehicle and a second memory option to remember a second height location such as height required to attach chains for a weight distributing hitch.

While unhooking from the tow vehicle, Extend/Retract the jack to the desired location that allows the coupler to clear the hitch ball and unhook the trailer from the tow vehicle. This is the position that jack will return to while hooking back up to the tow vehicle by following these steps:

1. Push and hold the **Mem 1** Memory Button for three (3) seconds and the GREEN light flashes three (3) times to set the memorized position of the jack at the desired height.
2. Once the Memory position has been set, pushing the **Mem 1** button will take the jack to the memorized location.
3. Once the jack is traveling to the memory location and user wants to stop the jack for whatever reason, press the memory button again and the jack will stop. To resume the memory function, press the memory button and the jack will proceed to the memory location.
4. Otherwise, use the Extend and Retract buttons to operate the jack. The memory button should only be used to set the memory location and to travel to the memory location.
5. To set the second memory position follow steps 1 through 4 using the **Mem 2** button instead of the **Mem 1** button.

MOTOR/GEAR ASSEMBLY

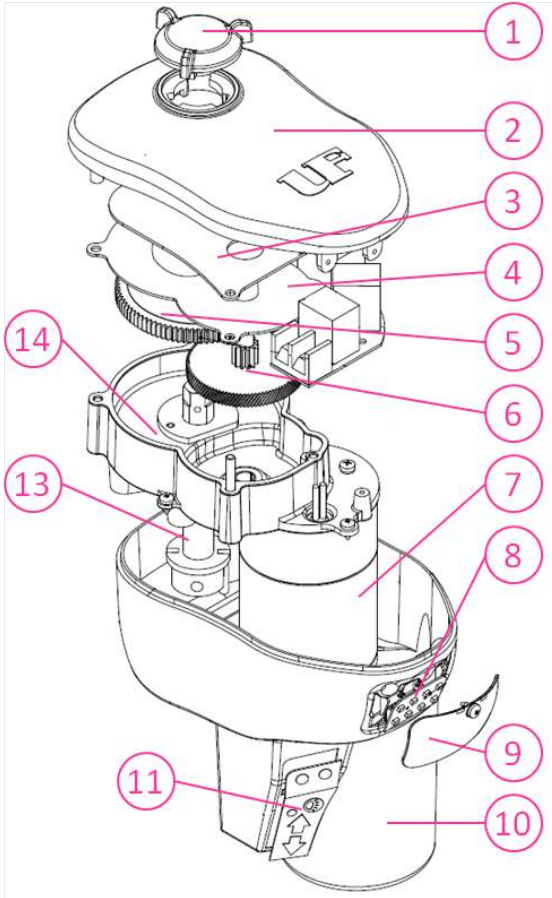

#	PART #	DESCRIPTION	QTY
1	35-753001	Twist Plug	1
2	35-753002	Plastic Housing Cover	1
3	38-753019	PCB-Main	1
4	38-753012	Gear Box Cover	1
5	38-753013	Drive Gear	1
6	38-753014	Bevel Gear Assembly	1
7	38-753016	Motor	1
8	38-753015	LED Light	1
9	38-753003	Lens	1
10	38-753004	Motor Housing	1
11	38-753005	Keypad	1

PARTS VIEW

#	PART #	DESCRIPTION	QTY
13	38-753021	Collar	1
14	38-753017	Gear Box	1
15	38-753026	Outer Tube	1
16	38-141023	Wire Lock Pin	1
17	38-751101	Footpad Adjustable	1
18	38-753033	Inner Tube	1
19	38-753010	Ball Screw Set	1
20	38-753024	Brake Assembly	1
21	38-753025	Friction Washer	1

NOT SHOWN	PART #	DESCRIPTION	QTY
	38-751167	Manual Override Socket - 9/16"	1
	38-751034	250V 30A Slow-Blow Fuse	1
	38-751035	Fuse Holder	1

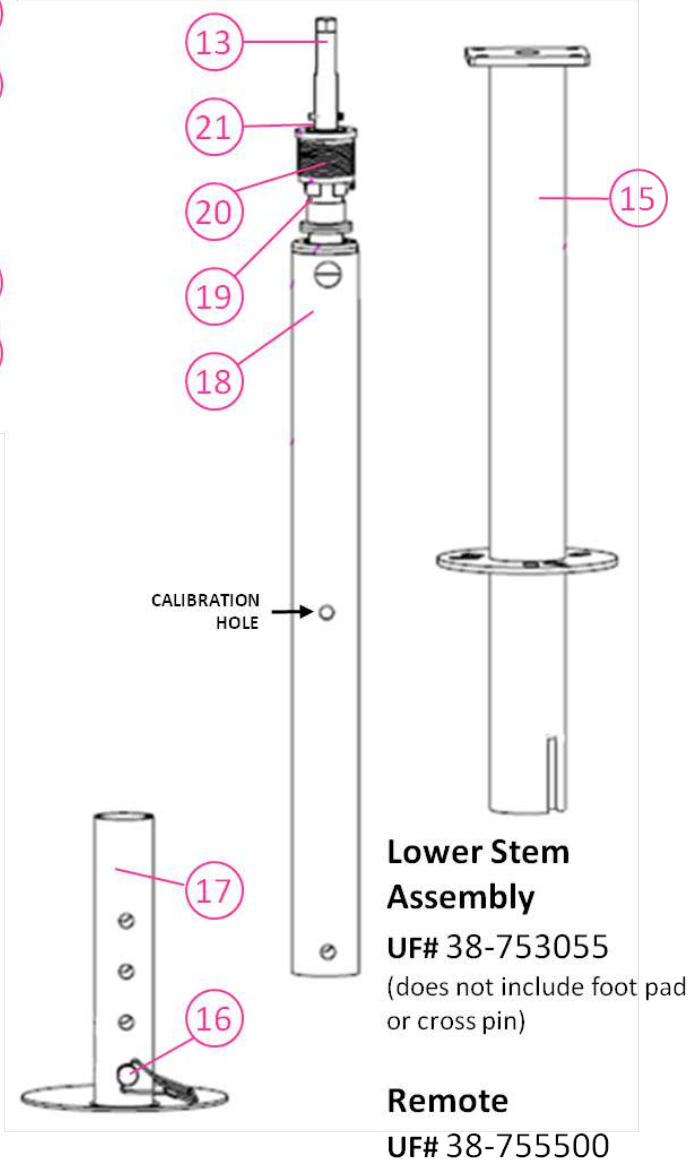

PHOENIX 5500 WIRING DIAGRAM

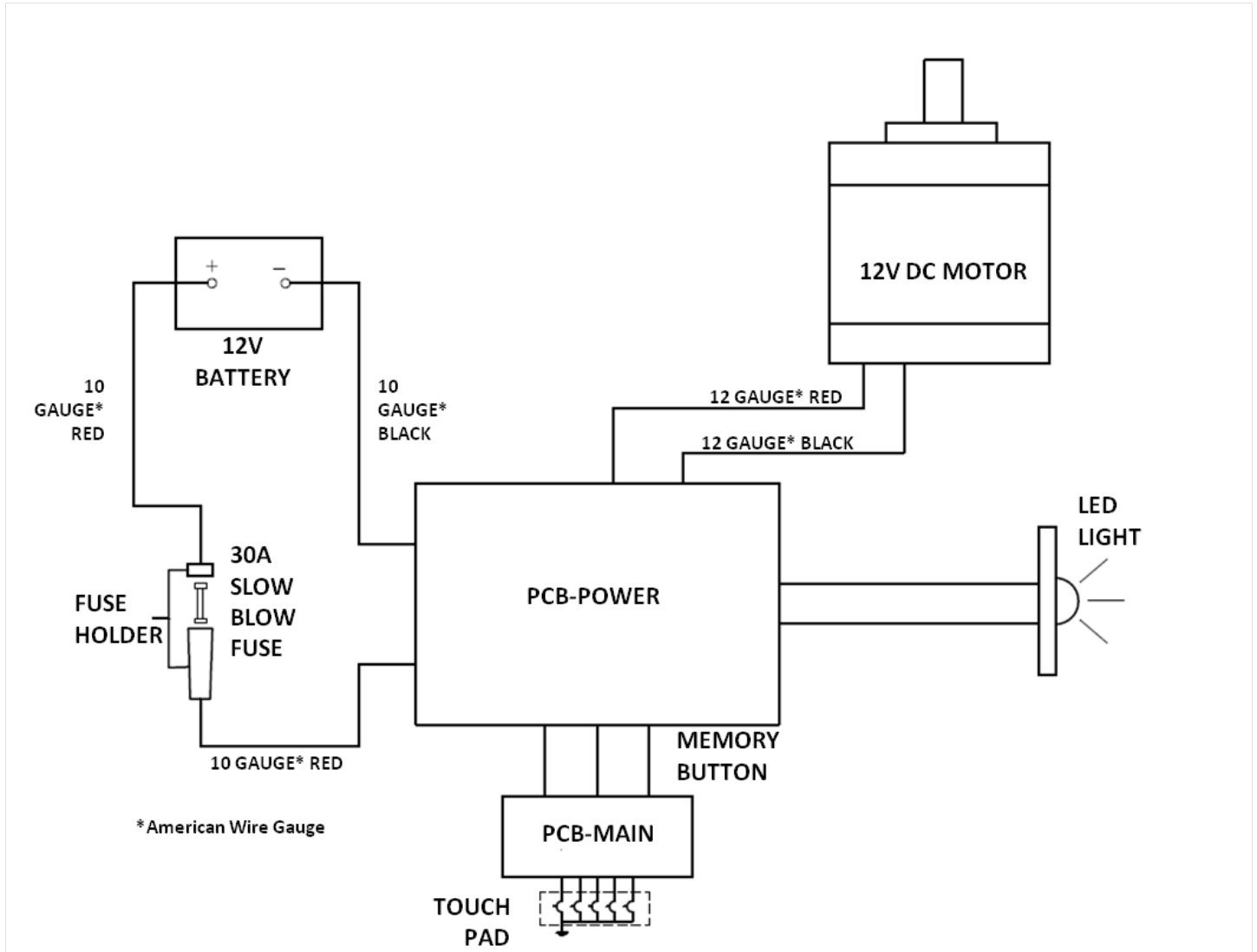



PHOENIX 5500 ELECTRIC TONGUE JACK

P/N 38-944055

US PATENT 10,252,591 B1



TWO-YEAR LIMITED WARRANTY

PHOENIX 4000/5500 TONGUE JACKS

THE MANUFACTURER NAMED BELOW MAKES THE FOLLOWING WARRANTY WITH RESPECT TO THE ABOVE ULTRA-FAB PRODUCTS

1. This Warranty is made only to the first Purchaser (hereinafter called the "Original Purchaser") who acquires this product for their own use.
2. This Warranty will be in effect for two years from the date of purchase by the Original Purchaser. It is suggested that the Original Purchaser retain a copy of the dated bill of sale as proof of the date of purchase.
3. This Warranty covers only specified parts which shall be free from defects in material and workmanship under normal use. This Warranty does not cover conditions unrelated to the material and workmanship of the product. Such unrelated conditions include, but are not limited to (a) faulty installation and any damage resulting from such; (b) the need for normal maintenance and any damage resulting from the failure to provide such maintenance; (c) failure to follow Manufacturer's instructions for use of this product, and (d) any accident to, or misuse of, any part of this product and any alteration by anyone other than the Manufacturer or its authorized representative.
4. In order to obtain the benefits of this Warranty, you should return the product which you find defective to the Manufacturer named below during the period that this Warranty is in effect. All charges incurred in delivery of the product to the Manufacturer, and in picking it up after the Warranty service has been completed, must be paid by the Original Purchaser.
5. Any item returned in the manner described in paragraph 4 will be examined by the Manufacturer. If it is found that the returned item was defective in material or workmanship, the Manufacturer will repair it without charge for material and labor.
6. Ultra-Fab will pay freight on replacement parts during the first 90 days of ownership by the Original Purchaser.
7. The Manufacturer does not authorize any person or company to create any Warranty obligation or liability on their behalf.
8. IN NO EVENT SHALL THE MANUFACTURER BE LIABLE FOR INCIDENTAL OR CONSEQUENTIAL DAMAGES. SOME STATES DO NOT ALLOW THE EXCLUSION OR LIMITATION OF INCIDENTAL OR CONSEQUENTIAL DAMAGES SO THE ABOVE LIMITATION OR EXCLUSION MAY NOT APPLY TO YOU.
9. ANY IMPLIED WARRANTY, INCLUDING THE IMPLIED WARRANTY OF MERCHANTABILITY AND FITNESS FOR ANY PURPOSE, IS LIMITED TO THE DURATION OF THIS LIMITED WARRANTY. SOME STATES DO NOT ALLOW LIMITATIONS ON HOW LONG AN IMPLIED WARRANTY LASTS, SO THE ABOVE LIMITATION MAY NOT APPLY TO YOU.
10. THIS WARRANTY GIVES YOU SPECIFIC LEGAL RIGHTS, AND YOU MAY ALSO HAVE OTHER RIGHTS WHICH VARY FROM STATE TO STATE.

Ultra-Fab

WARRANTY REGISTRATION

Please visit our website www.ultra-fab.com
click on the **WARRANTY** tab and **REGISTER**
YOUR WARRANTY.

If you register your tongue jack within 90
days of purchase your warranty is extended
from 2-years to 10-years.

