



INSTALLATION/OPERATION



APPLICATION

The primary purpose of your Power Twin II is to provide rock solid stabilization for maximum comfort while using your RV in a parked position. To obtain this desired end result and eliminate the possibility of damage to your RV or the Power Twin II, it is very important to follow these step-by-step instructions.

IMPORTANT: DO NOT OPERATE THE POWER TWIN II BEFORE READING THE OPERATING INSTRUCTIONS.

The Power Twin II will assist you in final lifting and leveling, based on the Power Twin II Power Curve Graph which shows pounds of lift in relation to the ground clearance from the bottom of the frame.

By measuring the ground clearance on your RV you can determine the maximum amount of lift your Power Twin II will provide for final leveling.

NOTE: THE POUNDS OF LIFT INCREASES AS THE

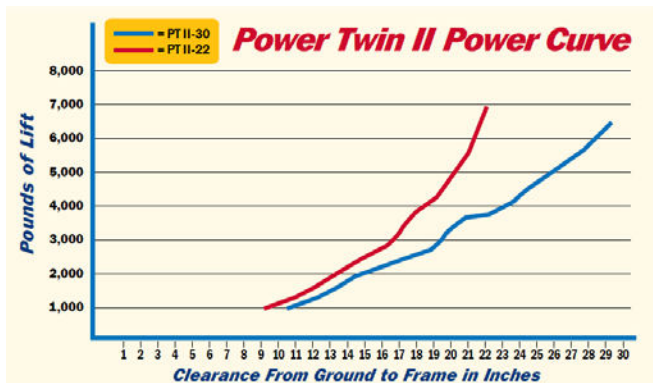

DISTANCE, FROM GROUND TO FRAME, INCREASES.

SAFETY AND DAMAGE WARNING



CAUTION: ALWAYS FOLLOW THESE INSTALLATION AND OPERATING INSTRUCTIONS TO PREVENT DAMAGE TO YOUR RV AND TO PREVENT PERSONAL INJURY.

INSTALLATION

The Power Twin II-30 does not come assembled. Please follow all of the steps of these instructions. The Power Twin II-22 is pre-assembled, so please skip to Step 3.

- 1 Attach mounting plate (#2) to main assembly channel (#1) using four (4) M8-1.25x25mm carriage bolts (#14) and four (4) M8x1.25 NYLOCK nuts (#15). Make sure the mounting plate is square to the main channel assembly before tightening the nuts.
- 2 Attach the two (2) arm support braces (#13) to the mounting plate (#2) using two (2) M12-1.75x30mm hex head bolts (#16) and two (2) M12x1.75 NYLOCK nuts (#17).

Place the plastic washer (#11) between the arm and the mounting bracket. Attach the other end of the arm support braces to the leg assembly (#8) using one (1) M12-1.75x100mm hex head bolt (#18) and one (1) M12x1.75 NYLOCK nut (#17) by placing the leg spacer (#10) inside the leg assembly and pushing the bolt through the one side of the leg, through the spacer and out of the other side of the leg channel.

Be sure to place the plastic washer (#11) between the arm and the leg brace before pushing the bolt through the hole.

Tighten all bolts and nuts until snug. Do not over tighten as these are pivot points.

REPEAT steps 1 and 2 for the second leg assembly (39-841700 PTII-30).



3 Measure the outside width of the main frame channel of your RV. Lay out the two (2) Power Twin leg assemblies (see figure in this section below) and adjust the inside distance between the two (2) mounting plates to the same as the outside dimension of your RV frame.

Take the connecting bracket (#34) and position it over the two (2) side by side main channels (#1) and bolt by using eight (8) M8-1.25x25mm hex head bolts (#37) with the M8 flat washers (#36) and M8x1.25 NYLOCK nuts (#35).

Do not tighten at this time.

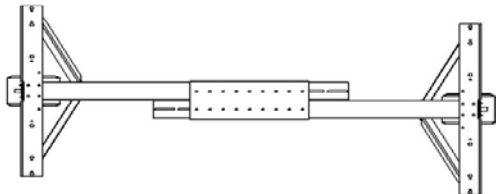

4 Attach the Power Twin assembly to the frame by using the holes provided in the mounting plate (#2) and (6 each side) 3/8" ***hex head bolts and nuts or 3/8" self drilling ***hex head screws.

DO NOT use any fasteners smaller than 1/4" diameter.

5 To finish assembly, go back and tighten the eight (8) bolts and nuts at the connecting bracket (#34).

6 Next step is to wire the switches to our motor assemblies and connect to the 12-volt power supply.

NOTE: In some installations, to achieve the maximum stabilization you require, it may be necessary to support the connecting bracket to the frame of your RV. We do not supply the brackets as there are many different configurations of cross members and in most installations it is not necessary.

***hardware not included

MOTOR INSTALLATION

1 Attach each of the motor and gear box assemblies (#22) to the Power Twin II with the four (4) M6-1.0x110mm hex bolts (#24) making sure the gasket (#27) is between the motor cover and the gear box.

NOTE: Make sure that the wires come out of the bottom side of the motor cover (towards the ground when installed).

REPEAT this step for the second motor and gear box assembly.

2 The switches may be mounted at any desired location, but a preferred location would be in a protected environment, such as a storage compartment or switch box near the jacks. **THE GOAL:** To be child-proof as well as weather-proof.

3 **CAUTION:** To avoid short circuits, remove the fuses (#28) from the fuse holders (#29) until the wiring is complete. Use 10 gauge (supplied) wires for the install. Using a smaller gauge wire will void the warranty. Join all wire connections with solder connections or crimp type connection. **DO NOT** use wire nuts as they tend to loosen and fall off.

4 Connect the GREEN wire to the negative terminal of the battery, or securely ground it to the frame (a clean and paint-free area).

5 Connect the WHITE wire to the positive terminal of the battery, or the nearest positive terminal block. Make sure to install the fuse holders (#29) on this WHITE wire, one on each switch. If running more than 15 feet of wire to access the battery, use a larger wire, such as 6 gauge wire. This will assure maximum performance. Voltage drop is a concern on long spans.

6 Connect the BLACK wire from the motor to the BLACK wire of the switch. Connect the RED wire from the motor to the RED wire of the switch (on each motor).



- 7 Replace the fuse (#28) and test the Power Twin II, one leg at a time. Check to see that the switches are wired in a logical relationship (UP position on the switch will raise the jack leg, DOWN position lower the jack leg).

EMERGENCY HANDLE USAGE/MANUAL OPERATION

- 1 Remove the fuses from the fuse holders.
- 2 Remove the four (4) bolts (ITEM# 24) holding the motor in place.
- 3 Place the pinned collar drive on the handle over the slotted collar and turn the crank the appropriate direction to either extend the Power Twin II leg or retract it.

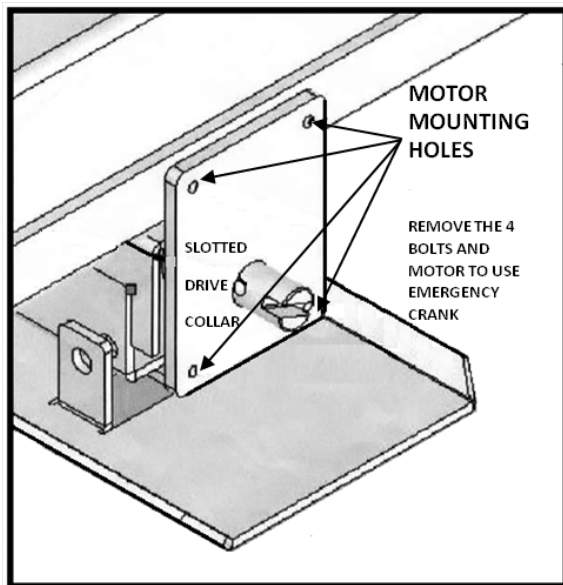

INSTRUCTIONS FOR USE

TRAVEL TRAILER OR 5TH WHEELS

- 1 Chock your wheels and level your RV from front to back by using your tongue jack or landing gear.
- 2 Using a level, determine which side of our RV is the lowest and extend the jack(s) on that side until your RV is level.
- 3 Extend the jack(s) on the opposite side of the RV until they touch the ground firmly. Your RV is now in its most stable position.
- 4 You can retract all of the jacks simultaneously.

CLASS C MOTOR HOMES

- 1 Set your brakes.
- 2 Extend the jack on the low side of your Class C motor home until the rear is level.
- 3 Extend the opposite side until it touches the ground firmly. Your RV is now in its most stable position.



CAUTION:

ALWAYS RETRACT POWER TWIN II BEFORE DEPARTING.

LUBRICATION

Each motor/gear assembly should be re-greased once per year through the grease fitting on the gearbox.

WARNING: DO NOT USE pneumatic-powered lube equipment as it can damage the leveler unit. Use hand-operated grease gun only.

Two pumps of chassis lube once per year is all that should be required. **DO NOT** over fill the gearbox with chassis lube as it could push into the motor causing damage to the motor.



Ultra-Fab Products, Inc.

57985 State Road 19, South
Elkhart, Indiana 46517

ULTRA POWER TWIN II-30
ULTRA POWER TWIN II-22

P/N 39-941705
P/N 39-941707

REV 12/2013

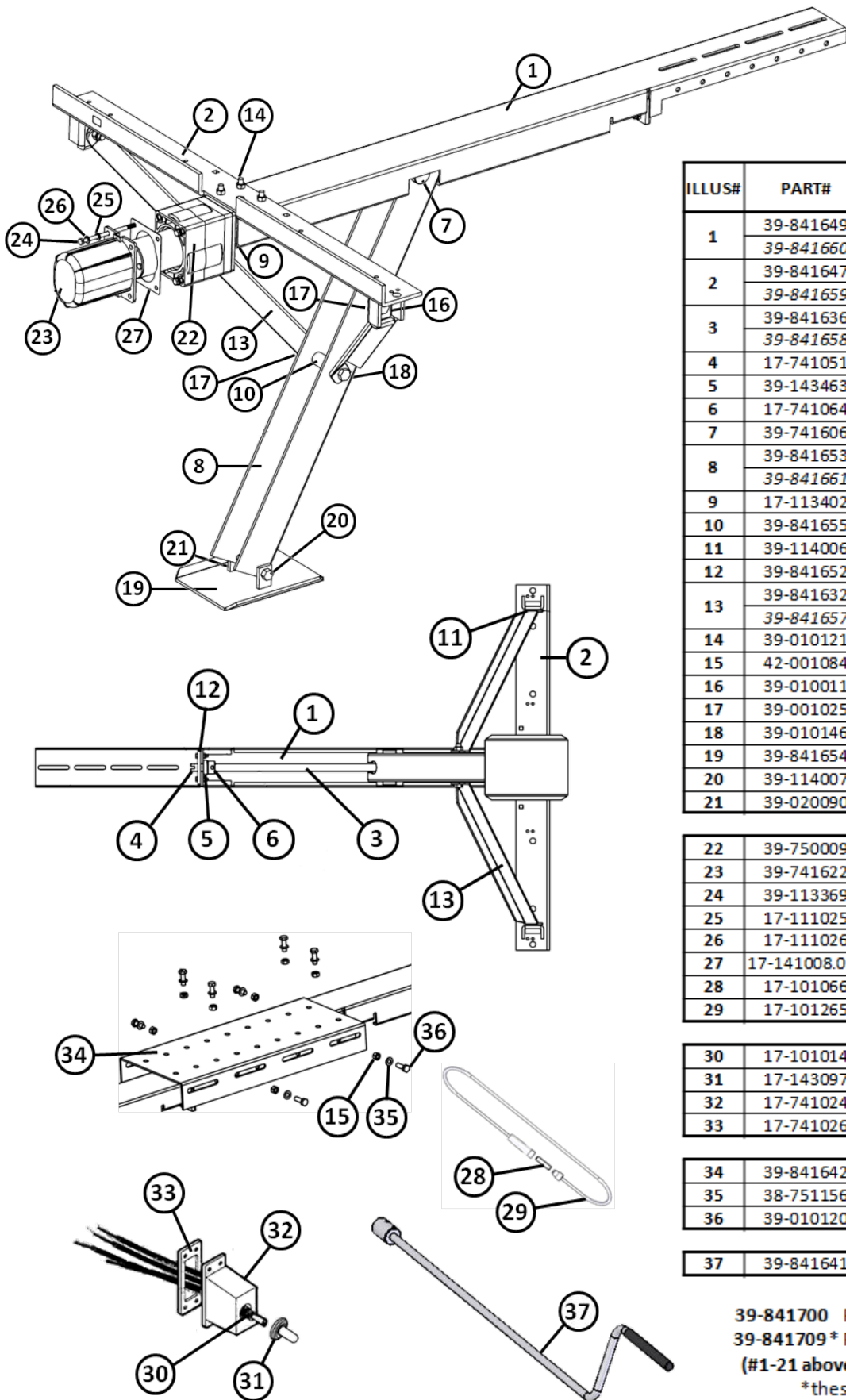

ILLUS#	PART#	PART NAME	TOTAL QTY REQ
1	39-841649	MAIN CHANNEL PTII-30	2
	39-841660	MAIN CHANNEL PTII-22*	2
2	39-841647	MOUNTING PLATE PTII-30	2
	39-841659	MOUNTING PLATE PTII-22*	2
3	39-841636	JACK SCREW PTII-30	2
	39-841658	JACK SCREW PTII-22*	2
4	17-741051	COLLAR	4
5	39-143463	BEARING	2
6	17-741064	ACME SCREW PIN	4
7	39-741606	JACK SCREW NUT	2
8	39-841653	MAIN LEG PTII-30	2
	39-841661	MAIN LEG PTII-22*	2
9	17-113402	FLAT WASHER 13/16 ID x 1.5 OD	4
10	39-841655	LEG SPACER	2
11	39-114006	PLASTIC WASHER	8
12	39-841652	RETAINING PLATE	2
13	39-841632	SUPPORT ARM PTII-30	4
	39-841657	SUPPORT ARM PTII-22*	4
14	39-010121	BOLT-M8-1.25x25mm CARRIAGE	8
15	42-001084	NUT-M8x1.25 NYLOCK	16
16	39-010011	BOLT-M12-1.75x30mm HEX	4
17	39-001025	NUT-M12x1.75 NYLOCK	6
18	39-010146	BOLT-M12-1.75x100mm HEX	2
19	39-841654	FOOTPAD	2
20	39-114007	BOLT-M10-1.5x100mm	2
21	39-020090	NUT-M10x1.5 NYLOCK	2

22	39-750009	MOTOR/GEAR BOX ASSY	2
23	39-741622	MOTOR HOUSING	2
24	39-113369	BOLT-M6-1.0x110mm HEX	8
25	17-111025	WASHER-M6 FLAT	8
26	17-111026	WASHER-M6 LOCK	8
27	17-141008.003	HOUSING GASKET	2
28	17-101066	FUSE 30A SLOW BLOW	2
29	17-101265	FUSE HOLDER	2

30	17-101014	MOTOR SWITCH W WIRE LEADS	2
31	17-143097	BOOT SEAL	2
32	17-741024	SWITCH HOUSING	2
33	17-741026	SWITCH COVER GASKET	2

34	39-841642	CONNECTING BRACKET	1
35	38-751156	WASHER-M8 FLAT	8
36	39-010120	BOLT-M8-1.25x25mm HEX	8

37	39-841641	HAND CRANK	1
----	-----------	------------	---

39-841700 POWER TWIN II-30 LEG ASSEMBLY (ONLY)

39-841709* POWER TWIN II-22 LEG ASSEMBLY (ONLY)

(#1-21 above - one side - 2 required to make the set)

*these parts are specific to the PTII-22



Ultra-Fab Products, Inc.

57985 State Road 19, South
Elkhart, Indiana 46517

**ULTRA POWER TWIN II-30
ULTRA POWER TWIN II-22**

**P/N 39-941705
P/N 39-941707**

REV 12/2013

THREE-YEAR LIMITED WARRANTY

DELUXE 5TH WHEEL LANDING GEAR, ULTRA SWAY CONTROL, WEIGHT DISTRIBUTION HITCH, BALL MOUNTS, HITCH BALLS, POWERTWIN II STABILIZERS, THE ELIMINATOR STABILIZER, LEVELING BLOCKS AND MANUAL TONGUE JACKS

**THE MANUFACTURER NAMED BELOW MAKES THE FOLLOWING WARRANTY WITH RESPECT TO THE ABOVE
ULTRA-FAB PRODUCTS**

1. This Warranty is made only to the first Purchaser (hereinafter called the "Original Purchaser") who acquires this product for their own use.
2. This Warranty will be in effect for three years from the date of purchase by the Original Purchaser. It is suggested that the Original Purchaser retain a copy of the dated bill of sale as proof of the date of purchase.
3. This Warranty covers only specified parts which shall be free from defects in material and workmanship under normal use. This Warranty does not cover conditions unrelated to the material and workmanship of the product. Such unrelated conditions include, but are not limited to (a) faulty installation and any damage resulting from such; (b) the need for normal maintenance and any damage resulting from the failure to provide such maintenance; (c) failure to follow Manufacturer's instructions for use of this product, and (d) any accident to, or misuse of, any part of this product and any alteration by anyone other than the Manufacturer or its authorized representative.
4. In order to obtain the benefits of this Warranty, you should return the product which you find defective to the Manufacturer named below during the period that this Warranty is in effect. All charges incurred in delivery of the product to the Manufacturer, and in picking it up after the Warranty service has been completed, must be paid by the Original Purchaser.
5. Any item returned in the manner described in paragraph 4 will be examined by the Manufacturer. If it is found that the returned item was defective in material or workmanship, the Manufacturer will repair it without charge for material and labor.
6. Ultra-Fab will pay freight on replacement parts during the first 90 days of ownership by the Original Purchaser.
7. The Manufacturer does not authorize any person or company to create any Warranty obligation or liability on their behalf.
8. IN NO EVENT SHALL THE MANUFACTURER BE LIABLE FOR INCIDENTAL OR CONSEQUENTIAL DAMAGES. SOME STATES DO NOT ALLOW THE EXCLUSION OR LIMITATION OF INCIDENTAL OR CONSEQUENTIAL DAMAGES SO THE ABOVE LIMITATION OR EXCLUSION MAY NOT APPLY TO YOU.
9. ANY IMPLIED WARRANTY, INCLUDING THE IMPLIED WARRANTY OF MERCHANTABILITY AND FITNESS FOR ANY PURPOSE, IS LIMITED TO THE DURATION OF THIS LIMITED WARRANTY. SOME STATES DO NOT ALLOW LIMITATIONS ON HOW LONG AN IMPLIED WARRANTY LASTS, SO THE ABOVE LIMITATION MAY NOT APPLY TO YOU.
10. THIS WARRANTY GIVES YOU SPECIFIC LEGAL RIGHTS, AND YOU MAY ALSO HAVE OTHER RIGHTS WHICH VARY FROM STATE TO STATE.

Ultra-Fab Products, Inc.

57985 SR 19 S., Elkhart, IN 46517

Tel: (574) 294-7571 Fax: (574) 294-4980

www.ultra-fab.com

**REGISTER
YOUR PRODUCT**

Please visit our website www.ultra-fab.com
click on the **WARRANTY** tab and select **REGISTER YOUR WARRANTY**.

As a registered ULTRA-FAB customer, you'll be able to:

- Stay informed of new products, announcements, and special offers.
- Get faster updates and news by including your email address.