



Thank you for purchasing the **Economy King Pin Tripod (PN 19-950500)**. It was a wise purchase, and we are sure it will provide you with many years of service.

! SAFETY WARNINGS !

This tripod is **NOT** a jack. It is **NOT** made to replace the landing gear on your 5th wheel trailer. This tripod is a stabilizer designed to reduce or eliminate the vibrations and motion that travel through the frame. **Do NOT** place your hands or fingers in areas that could cause pinching.

Assembly Instructions

The tripod hardware has been preassembled for your convenience. It is recommended to snug the nuts prior to placing the tripod on the king pin to provide better stability. Do not tighten completely. Allow the legs to move freely so that the tripod can open while being placed in use and can collapse upon removal from the king pin for easy storage. You will need to attach the footpad(s) - clip assembly supplied - and the chain.

How to Use

To use your tripod:

- 1) Run the chain (7) through all three leg brackets as pictured below.
- 2) Keep the chain loose and position the tripod below the king pin of your coach.
- 3) Lift the cup (1) up over the king pin.
- 4) Tighten and hook the chain to itself.
- 5) Turn the handle of the cup counter clockwise until the cup is snug against the king pin.
- 6) Two or three additional turns are normally sufficient for stabilization.
- 7) Your tripod is adjustable from 31" to 54".
- 8) Your tripod will support and stabilize up to 5,000 pounds.

To lock:

- 1) Place the lock (9) through the two holes in cup and lock. The neck of the lock has enough interference in the cup so that the king pin cannot be removed. **Your tripod is now stable and secure.**

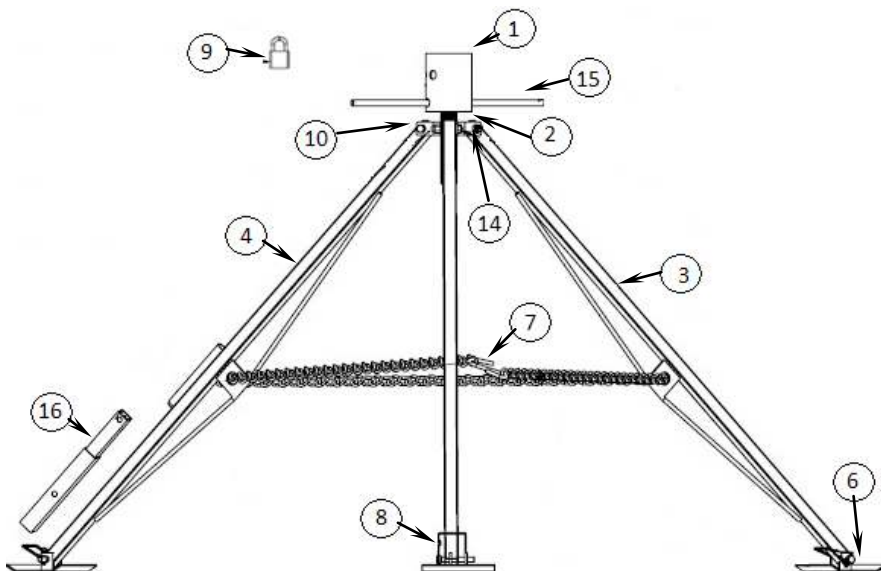

ILLUS. #	PART #	DESCRIPTION	QTY REQ
1	19-001081	KING PIN CUP ASSEMBLY	1
2	19-001082	LEG BRACKET	1
3	19-001083	LEG	2
4	19-001084	LEG WITH ROD HOLDER	1
6	19-001073	FOOTPAD	3
7	19-001085	CHAIN WITH S-HOOK	1
8	38-141023	CLIP ASSEMBLY	3
9	19-001022	PADLOCK	1
10	19-001020	BOLT- 3/8-16 x 2" HEX	3
14	38-020090	NUT- 3/8-16 NYLOCK	3
15	19-001007	ROD-CUP ADJUSTING	1
16	19-950002	EXTENSIONS-8" (OPTIONAL)	3