

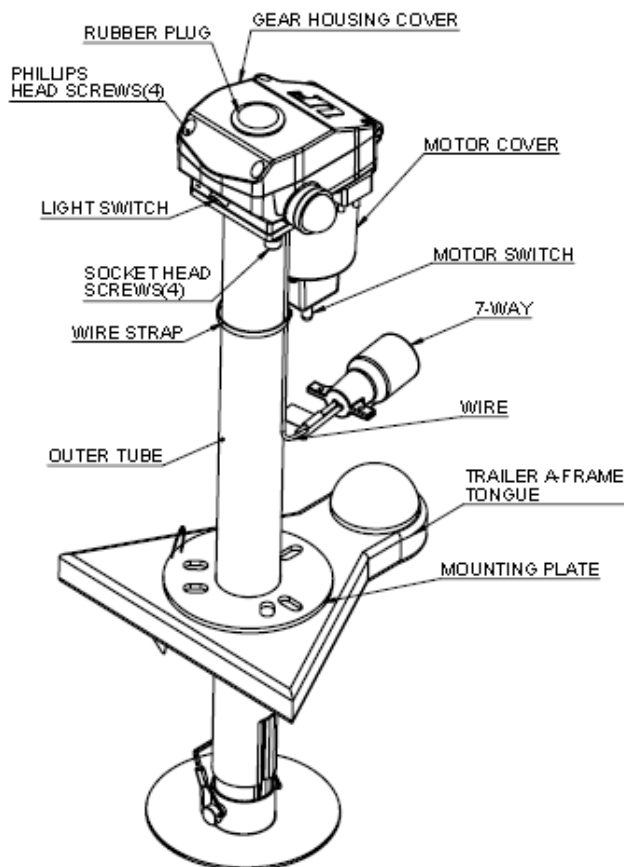

INSTALLATION/OPERATION



APPLICATION

The Ultra 3502-7 Electric Tongue Jack with the 7-Way Connector is a 12-volt motor-driven screw jack for use on travel trailers and boat trailers.

SPECIFICATIONS

Vertical Load: **3500** lbs. continuous over full stroke with 5000 instantaneous tongue breakaway capacity.

Travel – 18"

Power Requirement -12 volt D.C.

Model # 3502 - 2" outer tube w/ 1³/₄" inner tube

Retracted Height - 25¹/₂"

Removable Foot Pad -6" dia.

Approximate Shipping Weight – 22 lbs.

INSTALLATION

1. Block the wheels and support the trailer "A" frame securely.
2. Remove the existing jack.

NOTE: Save the original nuts, bolts, and washers for installing the Ultra 3502-7 Electric Tongue Jack.

3. The Electric Tongue Jack was designed to replace an existing crank down jack. The diameter of the outer tube of your chosen jack, will need to match the existing hole size, or you will need to modify the hole diameter to fit.

4. Depending on user's personal preference, align the motor head so that the motor housing is facing the front of the "A" frame or so the motor housing is facing the driver side of the trailer.
5. Insert 7-way plug into the 7-way receptacle on tow vehicle.

WARNING: DO-NOT use extension wire.

CAUTION: We do not recommend using the flip-up type footpad. Doing so requires the tongue jack to be altered which voids the warranty and can cause the failure of the jack.

OPERATION

1. Block trailer wheels securely.
2. Plug the Tongue Jack 7-Way connector into the 7-way male receptacle on the tow vehicle (after disconnecting your trailer 7-Way connector).
3. The Ultra 3502-7 Electric Tongue Jack is operated by means of the Toggle Switch located under the motor housing.
4. Extend the jack by holding the Toggle Switch in the Extend position.

CAUTION: The motor will stall if jack reaches the full extent of travel both in retract and extend directions. There is an over load protection for the jack to shut off power that will auto reset in 15 seconds. After using jack, operator should learn the travel limit stops. The operator should stop the jack before reaching the travel limit.

5. Retract the jack by holding the Toggle Switch in the Retract position. The jack is now fully retracted.

NOTE: If the motor should stall with the jack in the fully retracted position, and the Toggle Switch is not released, the motor will automatically switch off.

TROUBLESHOOTING: If you find the jack will not run, check to see if the lights to the jack turn on. If the lights do not turn on, the jack is not getting power.

1. Please check to make sure the CHARGE LINE from the tow vehicle is "hot" to the tow vehicle 7-way receptacle. Check the owner's manual of the tow vehicle to find the location of the fuse for the charge line to 7-way receptacle. Usually it is under the hood. Make sure the tow vehicle charge line is hooked up to the 7-way receptacle of the tow vehicle.
2. The 7-way plug to the jack may have a piece of plastic covering the connection left over from the creation of the plug – use a pocket knife to scrape away the plastic.
3. The tow vehicle may need to be running to make the charge line hot.

MANUAL OPERATION

1. Disconnect the 7-Way connector from the tow vehicle.
2. Remove plug cap in the access hole. (located top center of the housing cover)
3. Insert the 9/16" deep well socket (included) in the access hole, over the drive spindle tang. Rotate the socket clockwise to retract and counter clockwise extend.
4. When complete, remove socket and replace plug cap.



57985 State Road 19, South
Elkhart, Indiana 46517
PH: (800) 860-7571
FX: (800) 860-4980
www.ultra-fab.com

ULTRA 3502-7 ELECTRIC TONGUE JACK with 7-WAY PLUG

P/N 38-944037

US PATENT 9,821,774 B1

LUBRICATION

1. The jack is lubricated before leaving the factory. Under normal conditions, lubrication will be needed annually.
2. Grease the Jackscrew by extending the jack until the grease fitting is aligned with the hole in the outer tube. Using a standard grease gun and standard chassis lube, give two pumps.
3. Grease the gears in gearbox.

- a. Disconnect the 7-Way Connector from the tow vehicle.
- b. Remove the gear cover via 4 Phillips screws.
- c. Grease the gears with chassis lube and reinstall cover.

STORAGE

A hook and loop strap has been included to help store the wire/connector to the jack when not in use

MOTOR EXPLODED VIEW

No.	Part No.	Description	Q'ty
1	38-751030	Gear Housing Cover	1
2	38-751124	Pinion Gear 12T	1
3	38-751154	Pinion Key 3x6	1
4	38-751118	Spur Gear	1
5	38-101283	Circuit Breaker	1
6	38-751040	Motor	1
7	38-751037	Motor Switch	1
8	38-751047	Switch Housing	1
9	38-751039	Switch Boot	1
10	38-751060	Screw M4x8	6
11	38-751048	Motor Housing	1
12	38-751010	Screw M4x12	4
13	38-751042	Light	2
14	38-751057	Light Switch	1
15	38-751085	Main Gear	1
16	38-751070	Screw M4x16	4
17	38-751114	Rubber Plug	1
18	38-751090	7-Way Connector Assembly	1
19	38-751091	Strap-Hook/Loop	1

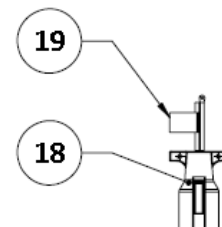
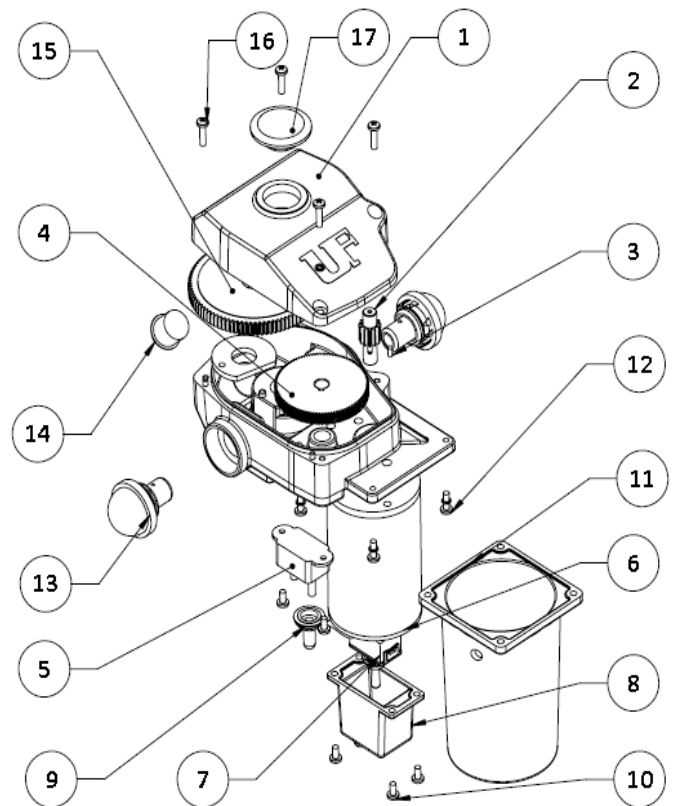

Not Shown	Part No.	Description	Q'ty
	38-751167	Socket 9/16" Deep Well / Manual Override	1



LOWER STEM ASSEMBLY EXPLODED VIEW

No.	Part No.	Description	Q'ty
1	38-752010	2" Outer Tube	1
2(A-F)	38-751160	1.75" Inner Tube Assembly	1
2A	38-751122	Collar Hex Head	1
2B	38-752018	Retaining Pin	1
2C	38-751121	Thrust Bearing	1
2D	38-751138	Cotter Pin	1
2E	38-751127	Upper Pin	1
2F	17-753230	Grease Zerk 6-1.0mm	1
3	38-751100	Footpad Standard 2" (3502)	1
4	38-141023	Wire Lock Pin	1

38-751170 – Lower Stem Assembly (Includes #1 & #2)

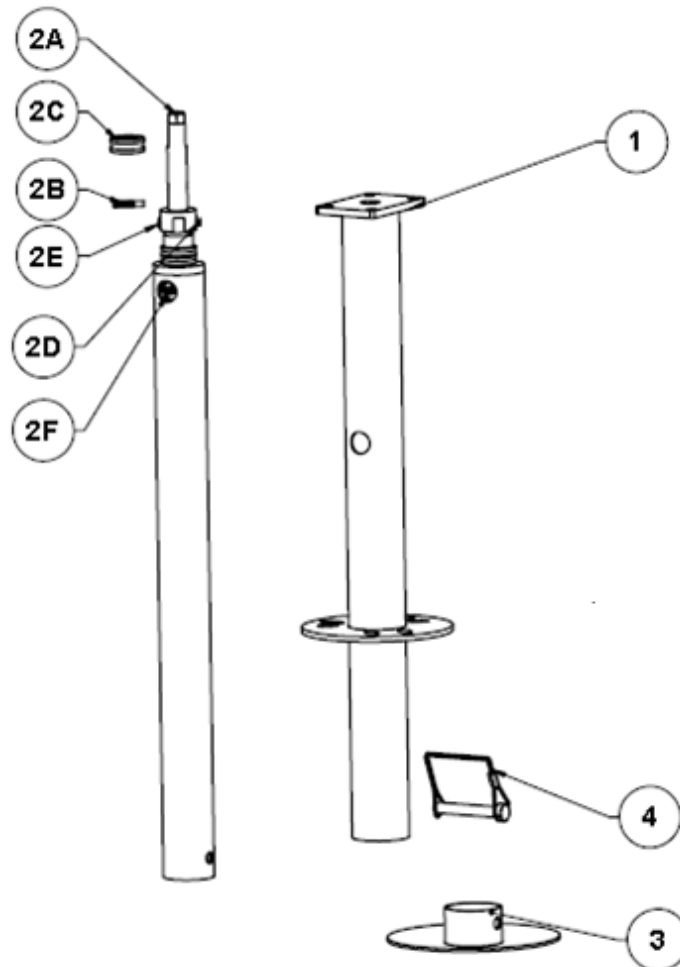



57985 State Road 19, South
Elkhart, Indiana 46517
PH: (800) 860-7571
FX: (800) 860-4980
www.ultra-fab.com

ULTRA 3502-7 ELECTRIC TONGUE JACK with 7-WAY PLUG
P/N 38-944037
US PATENT 9,821,774 B1

WIRING DIAGRAM

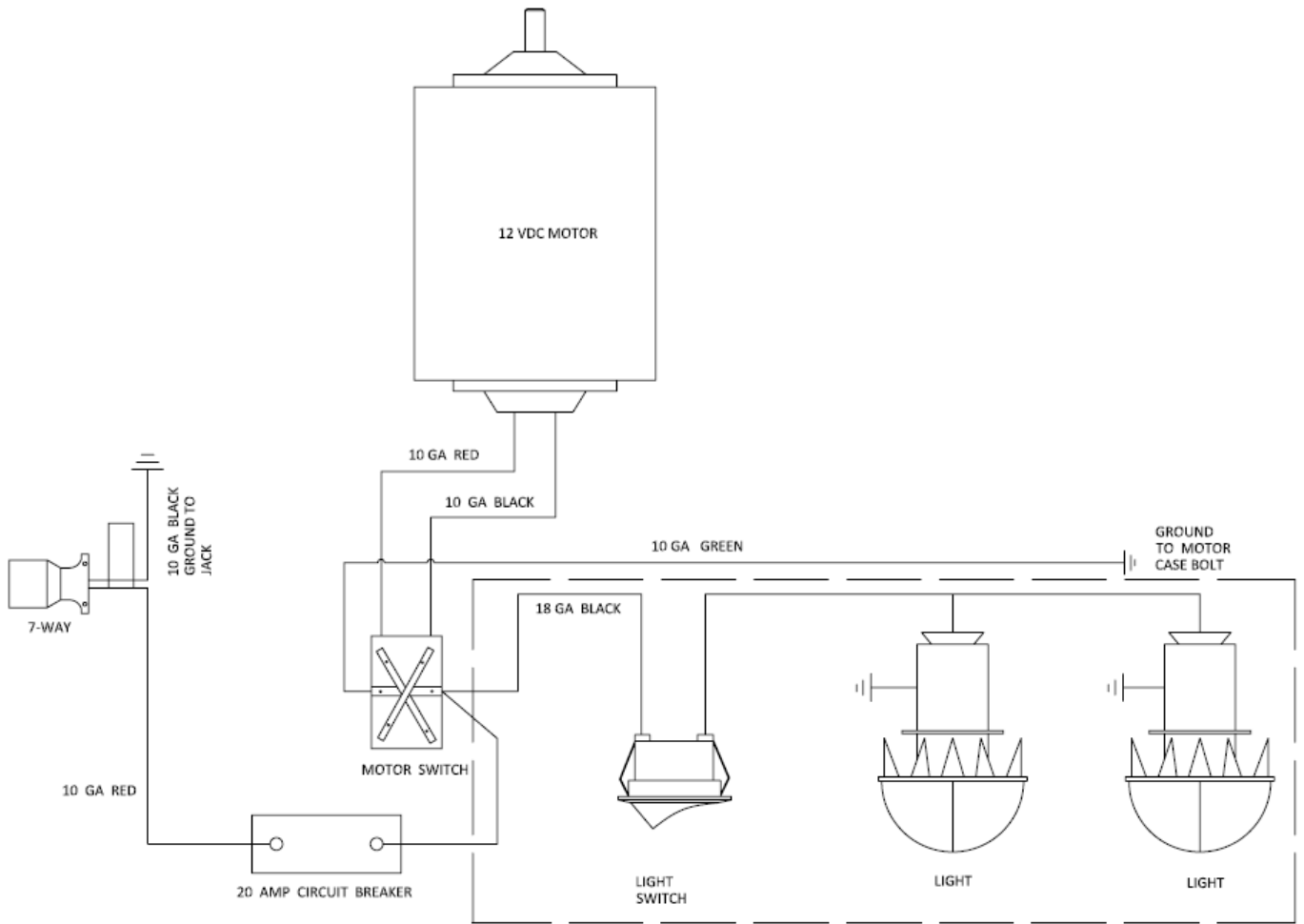



57985 State Road 19, South
Elkhart, Indiana 46517
PH: (800) 860-7571
FX: (800) 860-4980
www.ultra-fab.com

ULTRA 3502-7 ELECTRIC TONGUE JACK with 7-WAY PLUG

P/N 38-944037
US PATENT 9,821,774 B1

TWO-YEAR LIMITED WARRANTY ULTRA 3502/3502-7/4000/4002 TONGUE JACKS

THE MANUFACTURER NAMED BELOW MAKES THE FOLLOWING WARRANTY WITH RESPECT TO THE ABOVE ULTRA-FAB PRODUCTS

1. This Warranty is made only to the first Purchaser (hereinafter called the "Original Purchaser") who acquires this product for their own use.
2. This Warranty will be in effect for two years from the date of purchase by the Original Purchaser. It is suggested that the Original Purchaser retain a copy of the dated bill of sale as proof of the date of purchase.
3. This Warranty covers only specified parts which shall be free from defects in material and workmanship under normal use. This Warranty does not cover conditions unrelated to the material and workmanship of the product. Such unrelated conditions include, but are not limited to (a) faulty installation and any damage resulting from such; (b) the need for normal maintenance and any damage resulting from the failure to provide such maintenance; (c) failure to follow Manufacturer's instructions for use of this product, and (d) any accident to, or misuse of, any part of this product and any alteration by anyone other than the Manufacturer or its authorized representative.
4. In order to obtain the benefits of this Warranty, you should return the product which you find defective to the Manufacturer named below during the period that this Warranty is in effect. All charges incurred in delivery of the product to the Manufacturer, and in picking it up after the Warranty service has been completed, must be paid by the Original Purchaser.
5. Any item returned in the manner described in paragraph 4 will be examined by the Manufacturer. If it is found that the returned item was defective in material or workmanship, the Manufacturer will repair it without charge for material and labor.
6. Ultra-Fab will pay freight on replacement parts during the first 90 days of ownership by the Original Purchaser.
7. The Manufacturer does not authorize any person or company to create any Warranty obligation or liability on their behalf.
8. IN NO EVENT SHALL THE MANUFACTURER BE LIABLE FOR INCIDENTAL OR CONSEQUENTIAL DAMAGES. SOME STATES DO NOT ALLOW THE EXCLUSION OR LIMITATION OF INCIDENTAL OR CONSEQUENTIAL DAMAGES SO THE ABOVE LIMITATION OR EXCLUSION MAY NOT APPLY TO YOU.
9. ANY IMPLIED WARRANTY, INCLUDING THE IMPLIED WARRANTY OF MERCHANTABILITY AND FITNESS FOR ANY PURPOSE, IS LIMITED TO THE DURATION OF THIS LIMITED WARRANTY. SOME STATES DO NOT ALLOW LIMITATIONS ON HOW LONG AN IMPLIED WARRANTY LASTS, SO THE ABOVE LIMITATION MAY NOT APPLY TO YOU.
10. THIS WARRANTY GIVES YOU SPECIFIC LEGAL RIGHTS, AND YOU MAY ALSO HAVE OTHER RIGHTS WHICH VARY FROM STATE TO STATE.

Ultra-Fab Products, Inc.

57985 SR 19 S., Elkhart, IN 46517
Tel: (574) 294-7571 Fax: (574) 294-4980
www.ultra-fab.com



Ultra-Fab

**WARRANTY
REGISTRATION**

Please visit our website www.ultra-fab.com
click on the **WARRANTY** tab and **REGISTER**
YOUR WARRANTY.

If you register your tongue jack within 90
days of purchase your warranty is extended
from 2-years to 5-years.

