

## INSTALLATION/OPERATION

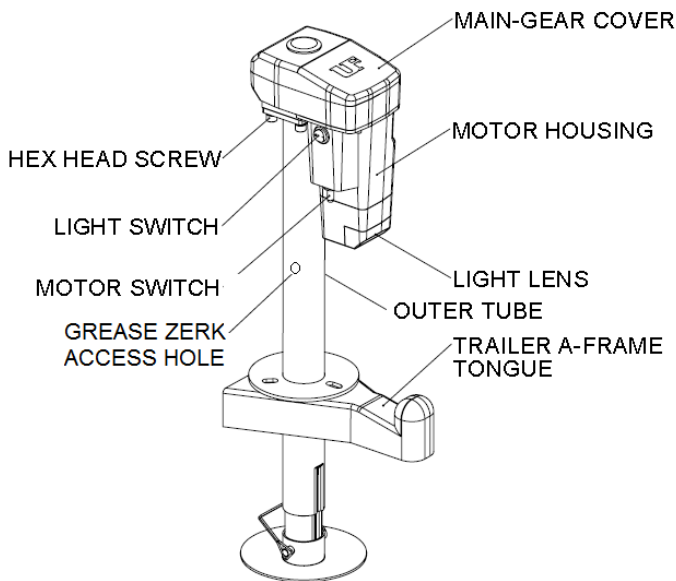

### APPLICATION

The Ultra 4002 Electric Tongue Jack is a 12-volt motor-driven screw jack for use on travel trailers, boat trailers, and cargo trailers.

### SPECIFICATIONS

Vertical Load – 4000 lbs. continuous over full stroke with 6000 lbs. instantaneous tongue breakaway capacity.

Travel – 18"

Power Requirement - 12V DC.

Outer Tube - 2"

Inner Tube – 1¾"

Retracted Height - 25½"

Removable Foot Pad - 5½" dia. (Adjustable)

Approximate Shipping Weight – 22 lbs.

### INSTALLATION

1. Block the wheels and support the trailer "A" frame securely.
2. Remove the existing jack.

**NOTE: Save the original nuts, bolts, and washers for installing the Ultra 4002 Electric Tongue Jack.**

3. Install the Electric Tongue Jack using original nuts and bolts. Depending on user's personal preference, align the motor head so that the motor housing is facing the front of the "A" frame or so that the motor housing is facing the driver side of the trailer.
4. The Electric Tongue Jack was designed to replace an existing manual jack. The diameter of the outer tube of your chosen jack, will need to match the existing hole size, or you will need to modify the hole diameter to fit.
5. Install Fuse Holder. By cutting the red wire loop, then either crimping or soldering the connections, attach one end to the positive post of the trailer battery. The other end of the fuse holder's red wire will be connected to the red wire from the jack. This red wire provides 12V power to jack.
6. Connect the red positive lead to the positive terminal of the battery. Connect the black ground wire to negative terminal of the battery.

**WARNING:** When using an extension wire, DO-NOT use smaller than #10 gauge wire.

**CAUTION:** We do not recommend using the flip-up type footpad. Doing so requires the tongue jack to be altered which voids the warranty and can cause the failure of the jack.

### OPERATION

1. Block trailer wheels securely.
2. The Ultra 4002 Electric Tongue Jack is operated by means of the Motor Switch located under the motor housing.
3. Extend the jack by holding the Motor Switch in the Extend position.

**CAUTION:** The motor will stall if jack reaches the full extent of travel both in retract and extend directions. There is an over load protection for the jack to shut off power that will auto reset in 15 seconds. After using jack, operator should learn the travel limit stops. The operator should stop the jack before reaching the travel limit.

4. Retract the jack by holding the Motor Switch in the Retract position. The jack is now fully retracted.

**NOTE:** If the motor should stall with the jack in the fully retracted position, and the Motor Switch is not released, the motor will automatically switch off.

### MANUAL OPERATION

1. Disconnect the fuse. (unscrew and pull apart)
2. Remove plug cap in the access hole. (located top center of the housing cover)
3. Insert the 9/16" socket in the access hole, over the drive hex head. Rotate the socket clockwise to retract and counter clockwise to extend.
4. When complete, remove socket and replace plug cap, and reassemble the fuse connection.

### LUBRICATION

The jack is lubricated before leaving the factory. Under normal conditions, lubrication will be needed after one year.

1. Grease the jackscrew by extending the jack until the grease fitting is aligned with the hole in the outer tube. Using standard chassis lube grease and a standard grease gun, give two pumps.
2. Grease the gears in gearbox.
  - a. Remove the fuse from fuse holder.
  - b. Using a 6mm Allen Wrench, remove the four socket head screws holding the motor/gear assembly to the top of the outer tube. Lift this assembly up and off. Unhook the wire connections in order to have enough slack to remove.
  - c. To remove the top of the gear/assembly first, remove the motor housing (4 screws). Two of the screws that hold the gear cover are under the motor housing.
  - d. Remove the gear cover (4) screws and lube gears with chassis lube.
  - e. Reassemble the gear/assembly.
  - f. Install the gear/assembly onto the lower stem, (it is helpful to remove the rubber plug) and look through the main gear in order to align the flats of the main gear in the gear/assembly with the flats of the drive collar of the lower stem. Turn collar to align flats if necessary.
  - g. Install the 6mm bolts and hook up wire connections.



57985 State Road 19, South  
Elkhart, Indiana 46517  
PH: (800) 860-7571  
FX: (800) 860-4980  
www.ultra-fab.com

**ULTRA 4002 ELECTRIC TONGUE JACK**  
**P/N 38-944016**  
**PATENT PENDING**

## MOTOR/GEAR ASSEMBLY

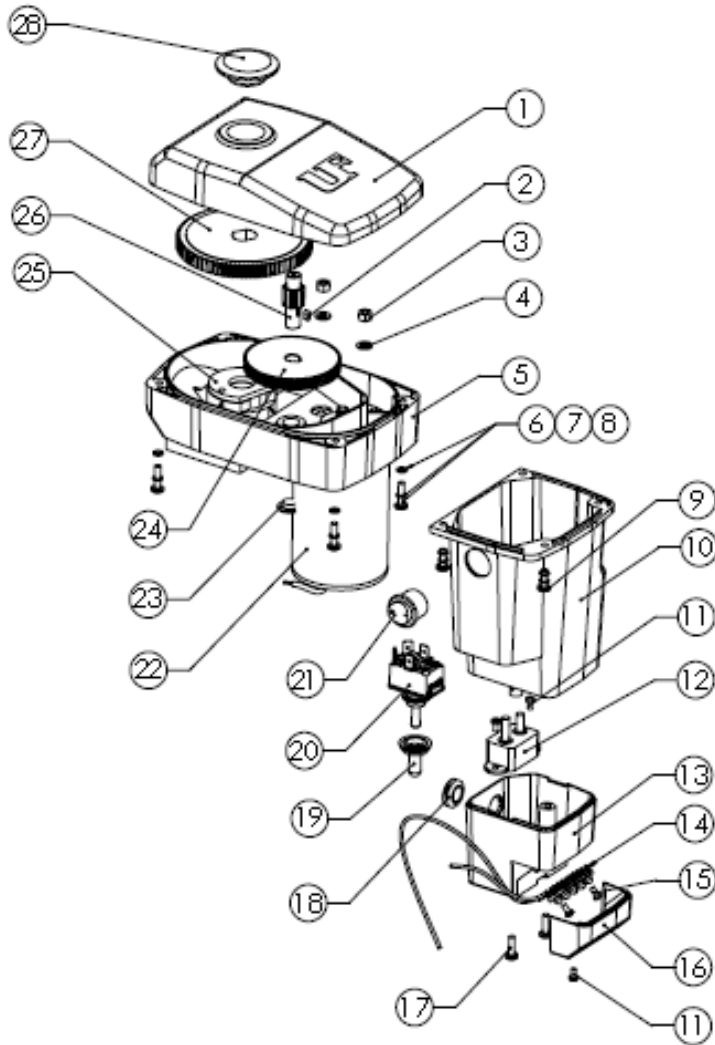

No.	Part No.	Part Name	Q'ty
1	38-752002	Gear Housing Cover	1
2	38-751154	Pinion Key 3x6	1
3	38-751152	Nut Nylon M5	2
4	38-751081	Washer 5mm Flat	2
5	38-752003	Main Gear Housing	1
6	38-751079	Lock Washer M4	8
7	38-751080	Spring Washer 4	8
8	38-751070	Screw - PPH M4x16	4
9	38-751010	Screw - PPH M4x12	4
10	38-752005	Motor Housing	1
11	38-751060	Screw - PPH M4x8	3
12	38-751142	Breaker - Circuit 12V 20A	1
13	38-752004	Light Housing	1
14	38-752006	LED Light	1
15	38-751140	Screw - ST2.9x6.5	2
16	38-752007	Light Lens	1
17	38-751174	Screw - ST4.2x13	2
18	38-751082	Grommet	1
19	38-751039	Switch Boot	1
20	38-751037	Motor Switch - on/off/on 250V 32A	1
21	38-751057	Light Switch - on/off 125/250V 6A	1
22	38-752008	Motor 150W 12VDC	1
23	38-751083	Rubber Plug	1
24	38-751118	Spur Gear 96T	1
25	38-751123	Washer Thrust	1
26	38-751124	Pinion Gear 12T	1
27	38-751085	Main Gear 89T	1
28	38-751114	Rubber Plug	1
29	38-751155	M8x25 Socket Head Cap Screw	4
30	38-751009	Lock Washer M8	4
31	38-114451	Lock Washer Internal Tooth M8	4

NOT SHOWN	Part No.	Part Name	Q'ty
	38-751167	Socket 9/16" Deep Well / Manual Override	1
	38-751034	250V 30A Slow-Blow Fuse	1
	38-751035	Fuse Holder	1



## LOWER STEM ASSEMBLY

No.	Part No.	Description	Q'TY
1	38-751102	2" Outer Tube	1
2(A-G)	38-751160	1.75" Inner Tube Assembly	1
2A	38-752018	Retaining Pin 5mm	1
2B	38-752019	Washer Spacer AS1730	1
2C	38-751138	Cotter Pin	1
2D	38-751127	Upper Pin	1
2E	38-751122	Collar Hex Head	1
2F	38-751121	Thrust Bearing	1
2G	17-753230	Grease Zerk 6-1.0mm	1
3	38-752020	Footpad Adjustable 2" (U4002)	1
4	38-141023	Wire Lock Pin	1

38-751170 Lower Stem Assembly (Includes #1 & #2)

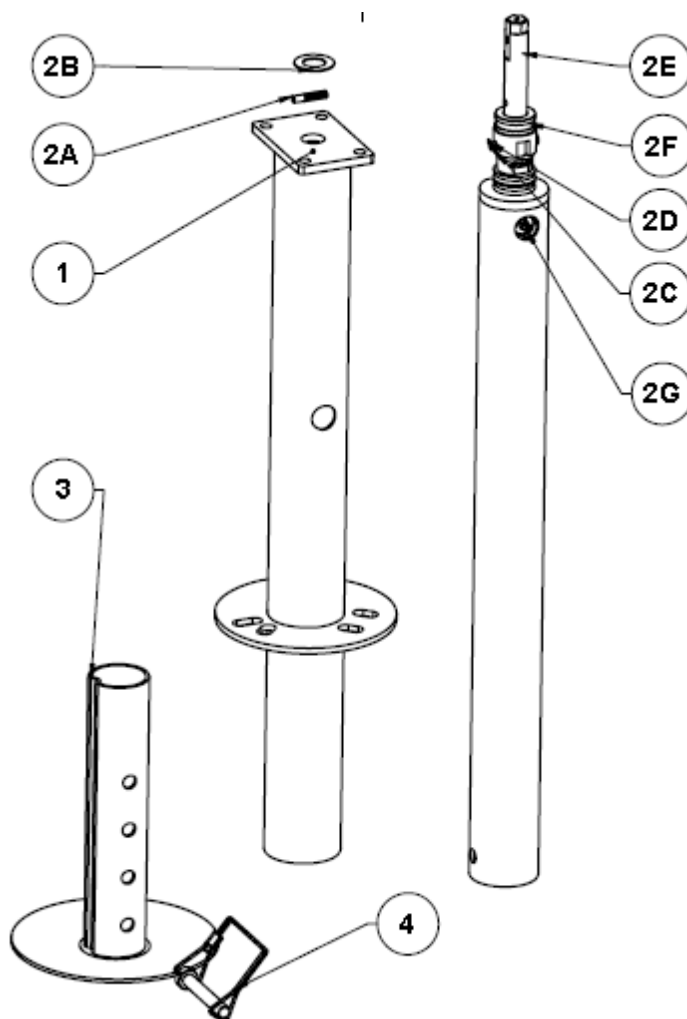



### WIRING DIAGRAM

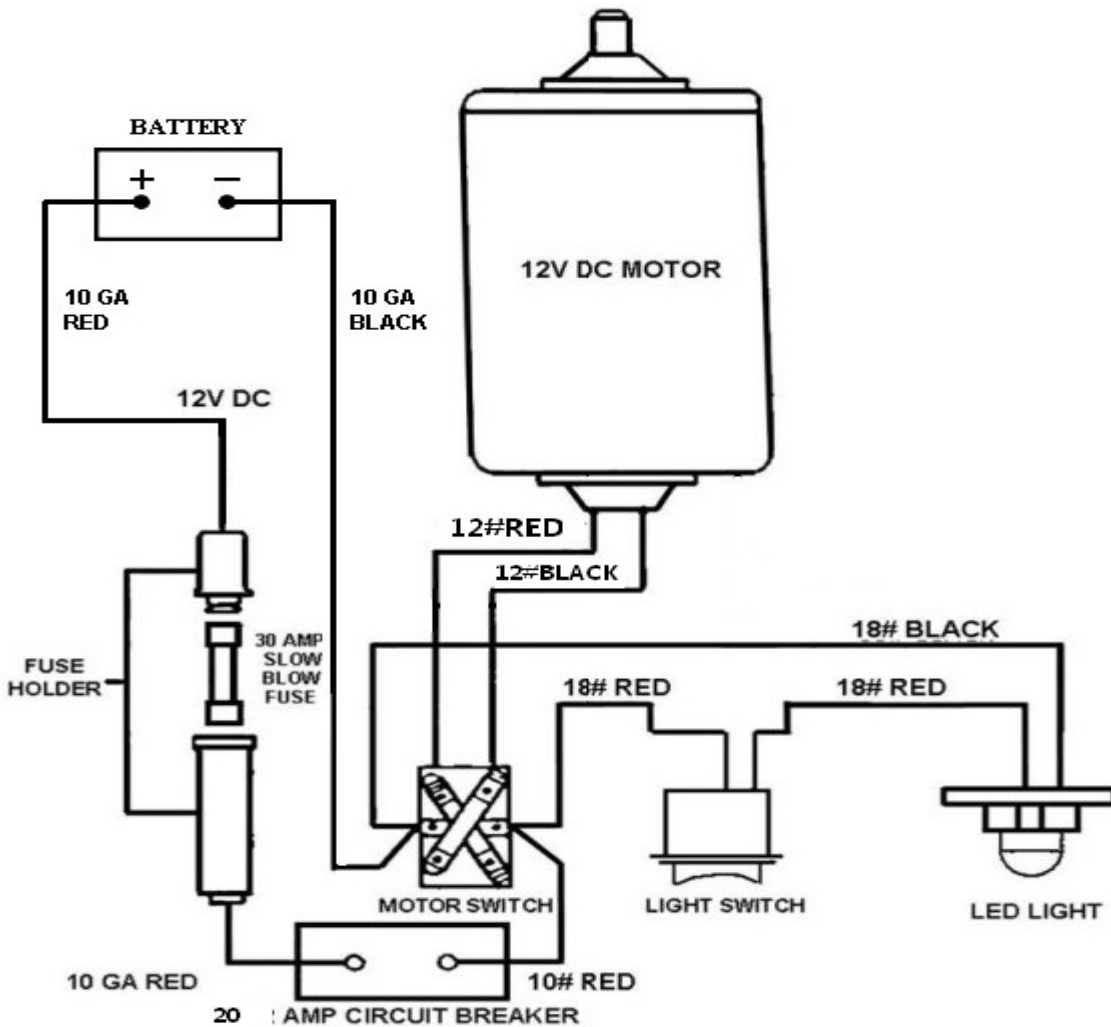



57985 State Road 19, South  
Elkhart, Indiana 46517  
PH: (800) 860-7571  
FX: (800) 860-4980  
www.ultra-fab.com

ULTRA 4002 ELECTRIC TONGUE JACK  
P/N 38-944016  
PATENT PENDING



Ultra-Fab Products, Inc.

## TWO-YEAR LIMITED WARRANTY

ULTRA 3502/3502-7/4000/4002 TONGUE JACKS

THE MANUFACTURER NAMED BELOW MAKES THE FOLLOWING  
WARRANTY WITH RESPECT TO THE ABOVE ULTRA-FAB PRODUCTS

1. This Warranty is made only to the first Purchaser (hereinafter called the "Original Purchaser") who acquires this product for their own use.
2. This Warranty will be in effect for two years from the date of purchase by the Original Purchaser. It is suggested that the Original Purchaser retain a copy of the dated bill of sale as proof of the date of purchase.
3. This Warranty covers only specified parts which shall be free from defects in material and workmanship under normal use. This Warranty does not cover conditions unrelated to the material and workmanship of the product. Such unrelated conditions include, but are not limited to (a) faulty installation and any damage resulting from such; (b) the need for normal maintenance and any damage resulting from the failure to provide such maintenance; (c) failure to follow Manufacturer's instructions for use of this product, and (d) any accident to, or misuse of, any part of this product and any alteration by anyone other than the Manufacturer or its authorized representative.
4. In order to obtain the benefits of this Warranty, you should return the product which you find defective to the Manufacturer named below during the period that this Warranty is in effect. All charges incurred in delivery of the product to the Manufacturer, and in picking it up after the Warranty service has been completed, must be paid by the Original Purchaser.
5. Any item returned in the manner described in paragraph 4 will be examined by the Manufacturer. If it is found that the returned item was defective in material or workmanship, the Manufacturer will repair it without charge for material and labor.
6. Ultra-Fab will pay freight on replacement parts during the first 90 days of ownership by the Original Purchaser.
7. The Manufacturer does not authorize any person or company to create any Warranty obligation or liability on their behalf.
8. IN NO EVENT SHALL THE MANUFACTURER BE LIABLE FOR INCIDENTAL OR CONSEQUENTIAL DAMAGES. SOME STATES DO NOT ALLOW THE EXCLUSION OR LIMITATION OF INCIDENTAL OR CONSEQUENTIAL DAMAGES SO THE ABOVE LIMITATION OR EXCLUSION MAY NOT APPLY TO YOU.
9. ANY IMPLIED WARRANTY, INCLUDING THE IMPLIED WARRANTY OF MERCHANTABILITY AND FITNESS FOR ANY PURPOSE, IS LIMITED TO THE DURATION OF THIS LIMITED WARRANTY. SOME STATES DO NOT ALLOW LIMITATIONS ON HOW LONG AN IMPLIED WARRANTY LASTS, SO THE ABOVE LIMITATION MAY NOT APPLY TO YOU.
10. THIS WARRANTY GIVES YOU SPECIFIC LEGAL RIGHTS, AND YOU MAY ALSO HAVE OTHER RIGHTS WHICH VARY FROM STATE TO STATE.

**Ultra-Fab Products, Inc.**

57985 SR 19 S., Elkhart, IN 46517  
Tel: (574) 294-7571 Fax: (574) 294-4980  
[www.ultra-fab.com](http://www.ultra-fab.com)

## EXTENDED WARRANTY



Ultra-Fab Products offers an EXTENDED WARRANTY on this jack.  
Please visit our website [www.ultra-fab.com](http://www.ultra-fab.com) click on the WARRANTY tab  
and select EXTENDED WARRANTIES.

YOU WILL NEED TO WRITE DOWN THE MODEL AND SERIAL NUMBERS  
FROM THIS TONGUE JACK. (located on the post of this jack)

Model Number: \_\_\_\_\_

Serial Number: \_\_\_\_\_

## REGISTER YOUR PRODUCT

Please visit our website  
[www.ultra-fab.com](http://www.ultra-fab.com)  
click on the WARRANTY tab and select  
REGISTER YOUR WARRANTY.

As a registered ULTRA-FAB  
customer, you'll be able to:

- Stay informed of new products, announcements, and special offers.
- Get faster updates and news by including your email address.