



INSTALLATION/OPERATION

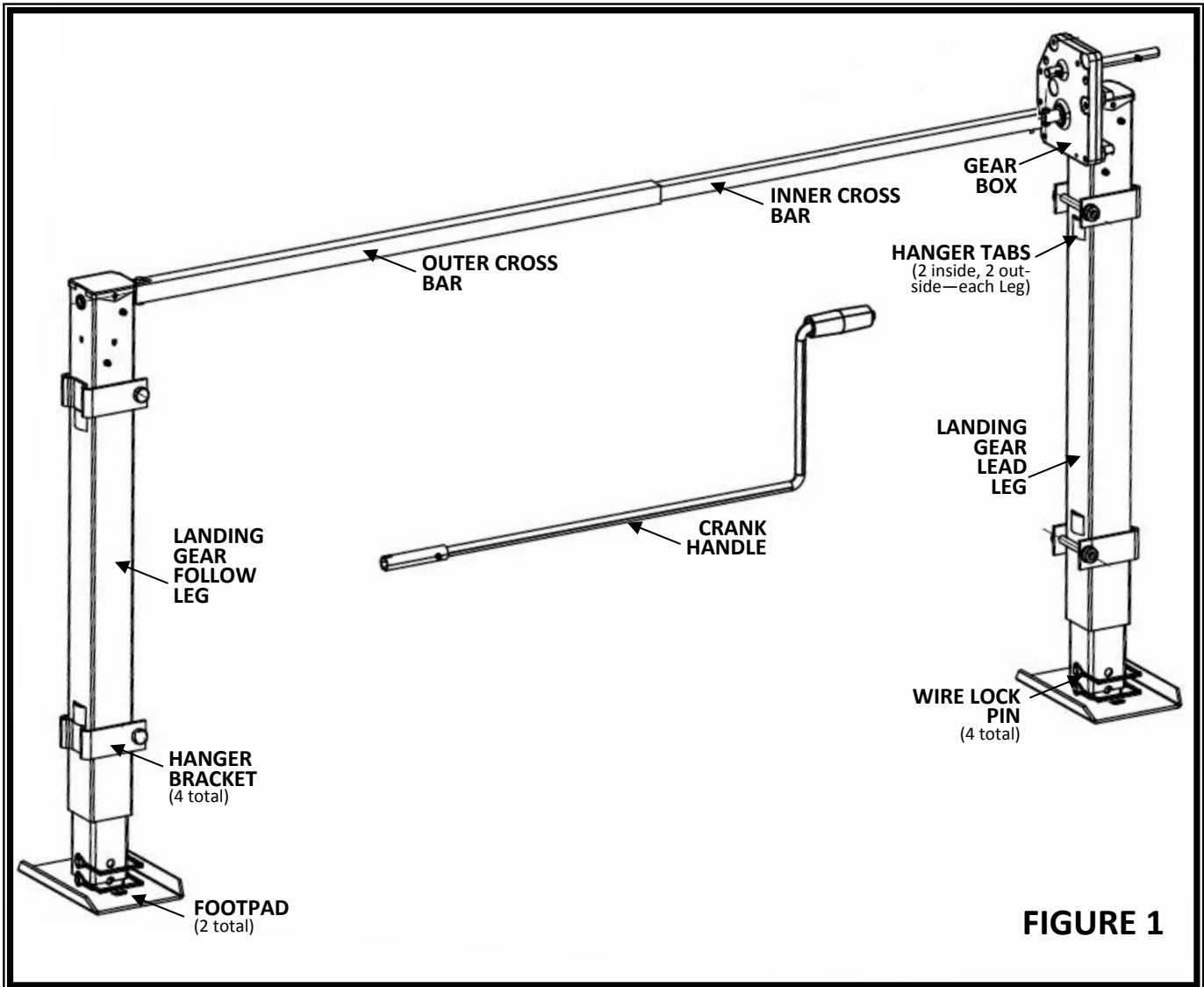

FIGURE 1

APPLICATION

The Ultra-Series Manual Landing Gear is designed and intended for use on all 5th wheel trailers.

INSTALLATION

TOOLS REQUIRED FOR INSTALLATION

- Pencil
- Measuring Tape
- Phillips-head Screw Driver
- Wrenches or Socket Set

SPECIFICATIONS

- Vertical Load – 6,000 lb. wt capacity combined
- Total Lift—37"
- Travel – 21"
- Drop Leg - 16"
- Retracted Height - 33"
- Outer Tube OD - 2¹/₄"
- Outer Tube Length—29¹/₂"
- Inner Tube OD - 2"
- Distance between hanger stops— 17¹/₂"
- Removable Foot Pad - 8"x 5"
- Approximate Shipping Weight – 70 lbs.



IMPORTANT

Read ALL of the following steps before beginning installation.

NOTE

The front end of the trailer should be raised up and supported at a comfortable working height. Remove existing landing gear. The Ultra-Series Manual Fifth Wheel Landing Gear Hangers should be welded on. Use of existing Hangers is acceptable if located properly.

ASSEMBLY & INSTALLATION

Gear Box can be oriented to three positions for Crank Handle locations depending on your set-up and access of the Crank Handle to the Manual Drive Input Shaft.

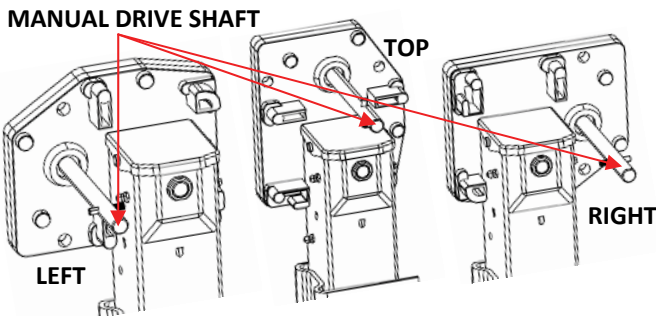

Place Gear Box on the lead leg with the drive 'D' Shaft. Slip the Gear Box Retaining Collar over the drive 'D' Shaft and attach with screw and fasten with lock nut.

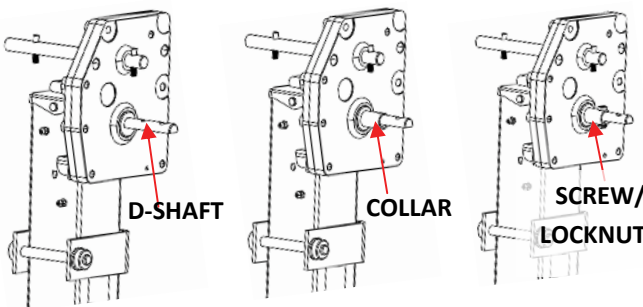

Attach the Footpad to the Inner Drop Tube on each jack leg using the square head Wire Lock Pin.

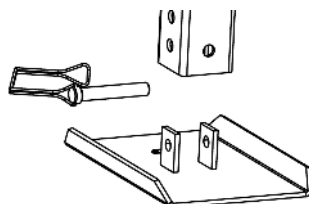

Rotate drive Shafts on both Lead and Follow Legs to fully retract landing Legs.

Attach Hanger Brackets to legs using carriage bolts and nuts. Torque bolts to 18-20 foot pounds on each leg, position one Hanger above and one below Hanger Tabs formed in the landing leg outer tube. (FIGURE 1 PAGE 1)



BLOCK WHEELS AND LEVEL TRAILER FOR SAFETY.

Position landing legs against frame in a vertical position. Locate Foot Pads and Wire Lock Pins for maximum ground clearance and to clear lower edge of trailer. We suggest the bottom of the outer tube of the jacks be just below the bottom of the trailer. The Manual Drive Shaft must be lined up to the access point for use of the Crank Handle. NOTE: The Follower Leg input should line up with the Lead Leg.



A CERTIFIED WELDER IS RECOMMENDED TO INSTALL THESE HANGER BRACKETS TO BE SURE PENETRATION OF THE WELDS AND METALS. FAILURE TO PROPERLY WELD HANGER BRACKETS TO THE FRAME CAN RESULT IN DAMAGE TO THE UNIT AND/OR SERIOUS INJURY OR DEATH.

Mark Hanger Bracket location on the trailer frame. Weld Hanger Bracket to the trailer frame on both vertical sides and across either top or bottom. DO NOT weld edges that contact Hanger Tabs and landing legs.

WELDER: USE 8MM FILLET WELD NO. E6011 AWS WELDING ROD 8MM DIAMETER. MACHINE AMPS (AC OR DCRP) @ 160-180 WITH 50 VOLTS.

Due to different frame configurations, it may be necessary to weld angle bracket to lower part of frame to locate landing legs vertically.

The Adjustable Cross Bar assembly (FIGURE 1 PAGE 1) ties the Gear Box to the Follow Leg. The Cross Bar assembly will telescope, helping you attach one end to the Gear Box and the other end to the Follow Leg assembly. The larger of



the telescoping tubes should be attached to the Follow Leg. Assemble the cross tubes by placing undrilled end of 20mm square tube (Inner Cross Bar) into undrilled end of the 25mm square tube (Outer Cross Bar).

Attach both landing legs to frame. Fully retract both Landing Legs before attaching Cross Bar assembly. Fasten drilled end of the smaller Inner Cross Bar to the end of the Shaft through Gear Box (Lead Leg) with the M16x25mm long bolt and lock nut. Bolt end of larger Outer Cross Bar to Shaft of Follow Leg with the M6x30mm long bolt and lock nut.

Check operation of landing Legs by inserting slotted end of Crank Handle through alignment tube and engage the end of Manual Drive Shaft. Rotate Crank Handle counter-clockwise. Check to see if both Legs are extending equally.



CAUTION—SECURE TRAILER BEFORE TRAVELING

Wire Lock Pin must be positioned around landing leg and secured over end of pin on opposite side of leg tube. This prevents pin from coming out during travel.

MANUAL OPERATION



OWNER OR OPERATOR MUST NEVER POSITION ANY PART OF THEIR BODY UNDER ANY PORTION OF THE JACK OR THE LOAD BEING SUPPORTED OR ALLOW ANYONE ELSE TO BE POSITIONED UNDER THE LOAD BEING SUPPORTED. DISREGARD COULD CAUSE PROPERTY DAMAGE AND/OR SERIOUS BODILY INJURY.

TO EXTEND THE LANDING LEGS: Place manual Crank Handle Coupler onto the Manual Drive Shaft of the Gear Box until it engages the Cross Bar assembly. Turn the Crank Handle counter-clockwise to extend the middle tube until it is about half way to the ground. This will optimize the overlap of all tubes, thus minimizing trailer sway. Then remove the Wire Lock Pin in the Drop Tube (inner tube with multiple holes) and let it drop to the ground and re-pin in the nearest adjustment hole.



MAKE CERTAIN THE DROP LEG SAFETY RETAINING PINS ARE FULLY INSERTED THROUGH BOTH SIDES OF THE INNER TUBE AND THE DROP LEG TUBE BEFORE USING THE LANDING GEAR JACKS.



NEVER ATTEMPT TO ADJUST THE DROP LEGS WHEN THE LANDING GEAR JACKS ARE UNDER LOAD.

Continue extending the landing Legs until the pin box disengages from the hitch and the weight of the trailer is completely removed from the hitch. When there is sufficient clearance between the pin box and the hitch, move tow vehicle clear of the trailer. Then lower the trailer until it is level, side-to-side and back-to-front. Remove and store the Crank Handle.



WARNING: DO NOT OVER-EXTEND THE LANDING GEAR. OVER-EXTENDING THE LANDING GEAR MAY RESULT IN DAMAGE TO THE DRIVE SHAFT PUTTING THE UNIT IN AN UNSAFE CONDITION AND WILL NOT BE COVERED BY THE PRODUCT WARRANTY.

TO RETRACT THE LANDING LEGS: Place manual Crank Handle coupler onto the Manual Drive Shaft of the Gear Box until it engages the Cross Bar. Turn the Crank Handle clockwise until the trailer is engaged in the hitch of the tow vehicle. Remove the pin or disengage the pull pin and raise the drop tubes of both legs, re-pinning it in the highest position. Fully retract the legs so that the Footpad is higher than the lowest part of the trailer, to prevent dragging while going over a curb. Remove and store the Crank Handle.

MAINTENANCE

Before use, inspect drop tube and middle tubes. Replace if bent or damaged.

ONCE EACH YEAR: Extend landing Legs as far as possible, clean drop tube and middle tube. Coat exposed surface of tubes with silicone spray lubricant.



ULTRA-SERIES MANUAL FIFTH WHEEL LANDING GEAR

UF# 17-943040

Coat inside of Handle alignment tube with silicone spray lubricant.

Oil Shaft bushing in Gear Box and Leg Gear heads with SAE 30 oil.

Lubricate Gears in Gear Box and landing Leg Gear heads with extreme pressure grease.

! THE 3:1 GEAR BOX IS NOT REPAIRABLE. DO NOT TAKE IT APART. IF YOU HAVE A PROBLEM WITH THE GEAR BOX, IT WILL NEED TO BE REPLACED.

ILLUS #	PART #	PART DESCRIPTION
1	17-861001	LEAD LEG ASSEMBLY
2	17-861002	FOLLOW LEG ASSEMBLY
3	17-861003	LEAD LEG GEAR BOX
4	17-861004	CROSS SHAFT ASSEMBLY
5	17-940006	FOOTPAD
6	38-141023	CROSS PIN
7	17-861005	CRANK HANDLE
8	17-741437	HANGER WITH NUT AND BOLT
9	17-861007	LEAD LEG REPAIR KIT
10	17-861008	FOLLOW LEG REPAIR KIT
11	17-861006	DROP TUBE REPLACEMENT

